

# Solar controller SR44

Installation and operating instructions



Read carefully before installation, commissioning and operation

# Table of content

<b>A. - Safety instructions</b>	<b>3</b>	6.2.2. - Type of pump	27	6.12. - Error message	37
A.1. - EC declaration of conformity	3	6.2.3. - Pump menu	28	6.13. - Pressure monitor	38
A.2. - General instructions	3	6.2.3.1. - Pump	28	6.13.1. - Pressure monitor	38
A.3. - Explanation of symbols	3	6.2.3.2. - Output Signal	28	6.13.1.1. - RPS1 / RPS2	38
A.4. - Changes to the unit	3	6.2.3.3. - PWM off	28	6.13.1.2. - Pmin	38
A.5. - Warranty and liability	4	6.2.3.4. - PWM on	28	6.13.1.3. - Pmax	38
A.6. - About the controller	4	6.2.3.5. - PWM Max	28	6.14. - Booster pump	38
A.7. - Scope of supply	4	6.2.3.6. - 0-10V off	28	6.14.1. - Filling time	38
A.8. - Disposal and pollutants	4	6.2.3.7. - 0-10V on	28	6.15. - Parallel operation R (X)	38
<b>B. - Description of controller</b>	<b>5</b>	6.2.3.8. - 0-10V Max	28	6.15.1. - Delay	38
B.1. - Specifications	5	6.2.3.9. - Speed when „On“	28	6.15.2. - Followup time	38
B.2. - Temperature resistance table for Pt1000 sensors	5	6.2.3.10. - Show signal	28	6.16. - Always on	39
<b>C. - Installation</b>	<b>6</b>	6.2.4. - Purging time	29	6.17. - Heating circuit	39
C.1. - Wall installation	6	6.2.5. - Sweep time	29	6.17.1. - Room set day	39
C.2. - Electrical connection	7	6.2.6. - max. speed	30	6.17.2. - Room set night	39
C.3. - Installing the temperature sensors	8	6.2.7. - min. speed	30	6.17.3. - Room sensor	39
C.4. - RC 21 Remote adjuster with thermostat 9		6.2.8. - Setpoint	30	6.17.4. - Periods	39
<b>D. - Terminal connection</b>	<b>10</b>	6.3. - Solar bypass	30	6.18. - Heat quantity	40
D.1. - Terminal connection	10	6.3.1. - Variant	30	6.18.1. - Flow sensor (X)	40
D.2. - Terminal connection diagram	10	6.3.2. - Bypass (sensor)	30	6.18.2. - Return sensor	40
D.3. - Hydraulic variants / Schemes / Systems11		6.4. - Thermostat	31	6.18.3. - Anti freeze type	40
<b>E. - Operation</b>	<b>19</b>	6.4.1. - TH Set	31	6.18.4. - Glycole percentage	40
E.1. - Display and input	19	6.4.2. - TH hysteresis	31	6.18.5. - Flow rate (X)	40
<b>E.2 Commissioning help</b>	<b>19</b>	6.4.3. - Thermostat sensor 1	31	6.18.6. - Offset Δ T	40
<b>E.3 Free commissioning</b>	<b>20</b>	6.4.4. - Thermostat sensor 2	31	6.18.7. - VFS (X)	40
<b>E.4 Menu sequence and menu structure</b>	<b>20</b>	6.4.5. - T eco	31	6.18.8. - VFS - Position	40
<b>1. - Measurement values</b>	<b>21</b>	6.4.6. - Storage	31	6.18.9. - Reference sensor	40
<b>2. - Statistics</b>	<b>21</b>	6.4.7. - Energy saving mode	31	6.18.10. - Pressure monitor	41
2.1. - Operating hours	21	6.4.8. - Periods	31	6.18.11. - Pressure monitor	41
2.2. - Heat output	21	6.5. - Cooling	32	6.18.11.1. - RPS1 / RPS2	41
2.3. - Graphic overview	21	6.5.1. - Co T set	32	6.18.11.2. - Pmin	41
2.4. - Message log	21	6.5.2. - Co hysteresis	32	6.18.11.3. - Pmax	41
2.5. - Reset/clear	21	6.5.3. - Cooling (sensor)	32	6.19. - Sensor calibration	41
<b>3. - Operating modes</b>	<b>22</b>	6.5.4. - Periods	32	6.20. - Commissioning	41
3.1. - Automatic	22	6.6. - Return flow increase	32	6.21. - Factory settings	41
3.2. - Manual	22	6.6.1. - RF Tmax	32	6.22. - SD-Card	42
3.3. - Off	22	6.6.2. - ΔT return flow	32	6.22.1. - Logging	42
3.4. - Fill system	22	6.6.3. - Return flow (sensor)	32	6.22.2. - Free storage	42
<b>4. - Settings</b>	<b>23</b>	6.6.4. - Storage (sensor)	32	6.22.3. - Load configuration	42
4.1. - Tmin S (X)	23	6.7. - Collector field cooling	33	6.22.4. - Save configuration	42
4.2. - Tmax S (X)	23	6.7.1. - Tmax field	33	6.22.5. - Firmware update	42
4.3. - Tmax SB	23	6.7.2. - Hys min	33	6.22.6. - Unmount	42
4.4. - Δ T Solar S (X)	23	6.7.3. - Hys max	33	6.23. - Start aid function	42
4.5. - Priority S(X)	24	6.7.4. - Field cooling sensor	33	6.24. - Time and date	42
4.6. - T-priority	24	6.8. - Anti Legionella	34	6.25. - Daylight saving time	42
4.7. - Loading time	24	6.8.1. - AL T set	34	6.26. - Sleep mode	43
4.8. - Increase	24	6.8.2. - AL residence time	34	6.27. - Ethernet	43
<b>5. - Protections / Protective functions</b>	<b>25</b>	6.8.3. - Last AL heat	34	6.27.1. - Ethernet	43
5.1. - System protection	25	6.8.4. - AL sensor 1	34	6.27.2. - MAC Adress	43
5.2. - Collector protection	25	6.8.5. - AL Sensor 2	34	6.27.3. - TCP/IP Adress	43
5.3. - Recooling	25	6.8.6. - AL-times	34	6.27.4. - Network Mask	43
5.4. - Frostschutz	26	6.9. - Heat transfer	35	6.27.5. - Gateway	43
5.5. - Seizing protection	26	6.9.1. - Δ T Heat transfer	35	6.27.6. - Login	43
5.6. - Collector alarm	26	6.9.2. - Setpoint	35	6.28. - Temperature unit	43
<b>6. - Special functions</b>	<b>27</b>	6.9.3. - HT Tmin	35	<b>7. - Menu lock</b>	<b>44</b>
6.1. - Program selection	27	6.9.4. - HT Source (sensor)	35	<b>8. - Service values</b>	<b>44</b>
6.2. - Speed control	27	6.9.5. - HT Drain (Target sensor)	35	<b>9. - Languages</b>	<b>44</b>
6.2.1. - Variant	27	6.10. - Difference	36	<b>Z.1 Malfunctions with error messages</b>	<b>45</b>
		6.10.1. - Δ T difference	36	<b>Z.2 Replacing the fuse</b>	<b>46</b>
		6.10.2. - DF source (sensor)	36	<b>Z.3 Maintenance</b>	<b>46</b>
		6.10.3. - Diff Tmin	36		
		6.10.4. - DF Drain (sensor)	36		
		6.10.5. - DF Tmax	36		
		6.11. - Solid fuel boiler	37		
		6.11.1. - SF Tmax	37		
		6.11.2. - SF Tmin	37		
		6.11.3. - Δ T SF	37		
		6.11.4. - Boiler sensor	37		
		6.11.5. - Storage sensor	37		

# Safety instructions

## A.1. - EC declaration of conformity

By affixing the CE mark to the unit the manufacturer declares that the SR44 conforms to the following relevant safety regulations:

- EC low voltage directive 2006/95/EC
- EC electromagnetic compatibility directive 2004/108/EC

Conformity has been verified and the corresponding documentation and the EC declaration of conformity are kept on file by the manufacturer.

## A.2. - General instructions

These installation and operating instructions contain basic instructions and important information regarding safety, installation, commissioning, maintenance and the optimal use of the unit. Therefore these instructions must be read completely and understood by the installation technician/specialist and by the system user before installation, commissioning and operation of the unit.

The valid accident prevention regulations, VDE regulations, the regulations of the local power utility, the applicable DIN-EN standards and the installation and operating instruction of the additional system components must also be observed. The controller does not under any circumstances replace any safety devices to be provided by the customer!

Installation, electrical connection, commissioning and maintenance of the unit may only be carried out by specialists who possess the appropriate training.

For the user: Make sure that the specialist gives you detailed information on the function and operation of the controller. Always keep these instructions in the vicinity of the controller.

## A.3. - Explanation of symbols



Failure to observe these instructions can result in danger to life from electric voltage.



Failure to observe these instructions can result in serious damage to health such as scalding, or even life-threatening injuries.



Failure to observe these instructions can result in destruction of the unit or the system, or damage to the environment.



Information which is especially important for the function and optimal use of the unit and the system.

## A.4. - Changes to the unit

- Changes, additions to or conversion of the unit are not permitted without the written permission from the manufacturer
- It is likewise forbidden to install additional components that have not been tested together with the unit
- If it becomes clear that safe operation of the unit is no longer possible, for example because of damage to the housing, then turn the controller off immediately
- Any parts of the unit or accessories that are not in perfect condition must be exchanged immediately
- Use only original spare parts and accessories from the manufacturer.
- Markings made on the unit at the factory must not be altered, removed or made illegible
- Only the settings actually described in these instructions may be made on the controller



Changes to the unit can compromise the safety and function of the unit or the entire system.

# Safety instructions

## A.5. - Warranty and liability

The controller has been manufactured and tested with regard to high quality and safety requirements. The unit is subject to the statutory guarantee period of two years from the date of sale.

The warranty and liability shall not include, however, any injury to persons or material damage that is attributable to one or more of the following causes:

- Failure to observe these installation and operating instructions
- Improper installation, commissioning, maintenance and operation
- Improperly executed repairs
- Unauthorised structural changes to the unit
- Installation of additional components that have not been tested together with the unit
- Any damage resulting from continued use of the unit despite an obvious defect
- Failure to use original spare parts and accessories
- Use of the device for other than its intended purpose
- Operation above or below the limit values listed in the specifications
- Force majeure

## A.6. - About the controller

The Temperature Difference Controller SR44 facilitates efficient use and function control of your solar or heating system. The device is impressive most of all for its functionality and simple, almost self-explanatory operation. For each step in the input process the individual entry keys are assigned to appropriate functions and explained. The controller menu contains head-words for the measured values and settings, as well as help texts or clearly-structured graphics.

The SR44 can be used as a solar controller for the various system variants illustrated and explained under „D.3. - Hydraulic variants / Schemes / Systems“ on page 11.

Important characteristics of the SR44:

- Depiction of graphics and texts in a lighted display
- Simple viewing of the current measurement values
- Analysis and monitoring of the system by means of statistical graphics, etc.
- Individual configuration of special functions
- Extensive setting menus with explanations
- Menu block can be activated to prevent unintentional setting changes
- Resetting to previously selected values or factory settings
- A wide range of additional functions are available.

## A.7. - Scope of supply

- Solar controller SR44
- 3 screws 3,5x35mm and 3 plugs 6mm for wall installation
- 12 strain relief clips with 24 screws, replacement fuse 1x T2A / 250V
- Installation and instructions manual SR44

Optionally contained depending on design/order:

- 2-8 PT1000 temperature sensors and immersion sleeves
- Ethernet

Additionally available:

- Pt1000 temperature sensor, immersion sleeves, overvoltage protection,
- CAN Bus Data Logger

## A.8. - Disposal and pollutants

The unit conforms to the European RoHS directive 2002/95/EC for the restriction of the use of certain hazardous substances in electrical and electronic equipment.



The unit must not under any circumstances be disposed of with ordinary household refuse. Dispose of the unit only at appropriate collection points or ship it back to the seller or manufacturer.

# Description of controller

## B.1. - Specifications

### Electrical specifications:

Mains voltage	100 - 240VAC
Mains frequency	50 - 60Hz
Power consumption	0,5 - 3 W
Switched power	
Entire switched power for electronic relays R1 - R2:	460VA for AC1 / 240W for AC3
Electronic relay R1	min.5W...max.120W for AC3
Electronic relay R2	min.5W...max.120W for AC3
Entire switched power for mechanical relays R3 - R6:	460VA for AC1 / 460W for AC3
Mechanical relay R3	460VA for AC1 / 460W for AC3
Mechanical relay R4	460VA for AC1 / 460W for AC3
Mechanical relay R5	460VA for AC1 / 460W for AC3
Mechanical relay R6	460VA for AC1 / 460W for AC3
potentialfree relay R7	460VA for AC1 / 460W for AC3

0..10V	Output for 10 k $\Omega$ working resistance
PWM	Output Freq. 1 kHz, level 10 V

Internal fuse	3x T2A / 250V slow blow
---------------	-------------------------

Protection category	IP40
Protection class	II
Overvoltage Category	II
Degree of Pollution Category	II

Sensor inputs	8 x Pt1000 temperature sensors 2x Grundfos Direct Sensors 1x RC21
---------------	---

Measuring range	
PT1000	-40°C to 300°C
Grundfos Direct Sensor:	0°C-100°C (-25°C /120°C short term) 1 l/min - 12 l/min (VFS1-12) 2 l/min - 40 l/min (VFS2-40) 5 l/min - 100 l/min (VFS5-100) 10 l/min - 200 l/min (VFS10-200)

### Permissible cable length of sensors and appliances:

Collector and outdoor sensor	<30m
other PT1000 sensors	<10m
VFS/RPS Sensoren	<3m
CAN	<3m
PWM / 0...10V	<3m
electronic relay	<3m
mechanical relay	<10m

### Network connections

Ethernet (optional)  
CAN Bus

Real Time Clock	RTC with 24 hour power reserve
-----------------	--------------------------------

### Permissible ambient conditions:

Ambient temperature	
for controller operation	0°C...40°C
for transport/storage	0°C...60°C
Air humidity	
for controller operation	max. 85% rel. humidity at 25°C
for transport/storage	no moisture condensation permitted

### Other specifications and dimensions

Housing design	3-part, ABS plastic
Installation methods	Wall installation, optionally panel installation
Overall dimensions	228 x 180 x 53 mm
Display	Fully graphical display, 128 x 128 dots
Light diode	2: 1x red, 1x green

## B.2. - Temperature resistance table for Pt1000 sensors

°C	0	10	20	30	40	50	60	70	80	90	100
$\Omega$	1000	1039	1077	1116	1155	1194	1232	1270	1308	1347	1385

# Installation



Caution

Install the controller only in dry areas and under the ambient conditions described under B.1 "Specifications".



Caution

Controller must be inaccessible from the rear.

## C.1. - Wall installation

1. Unscrew cover screw completely.
2. Remove Terminal connection cover. Unscrew the 2 small screws left and right and remove the upper part of the controller by lifting it out of the socket.
3. Mark the 3 mounting holes on the wall (see „C.1.1. Socket“). Make sure that the wall surface is even so that the housing does not become distorted when it is screwed on.
4. Using a drill and size 6 bit, drill 3 holes at the points marked on the wall and push in the plugs.
5. Hang the controller on the upper screw.
6. Align the housing and tighten the lower screws.

### C.1.1. Socket

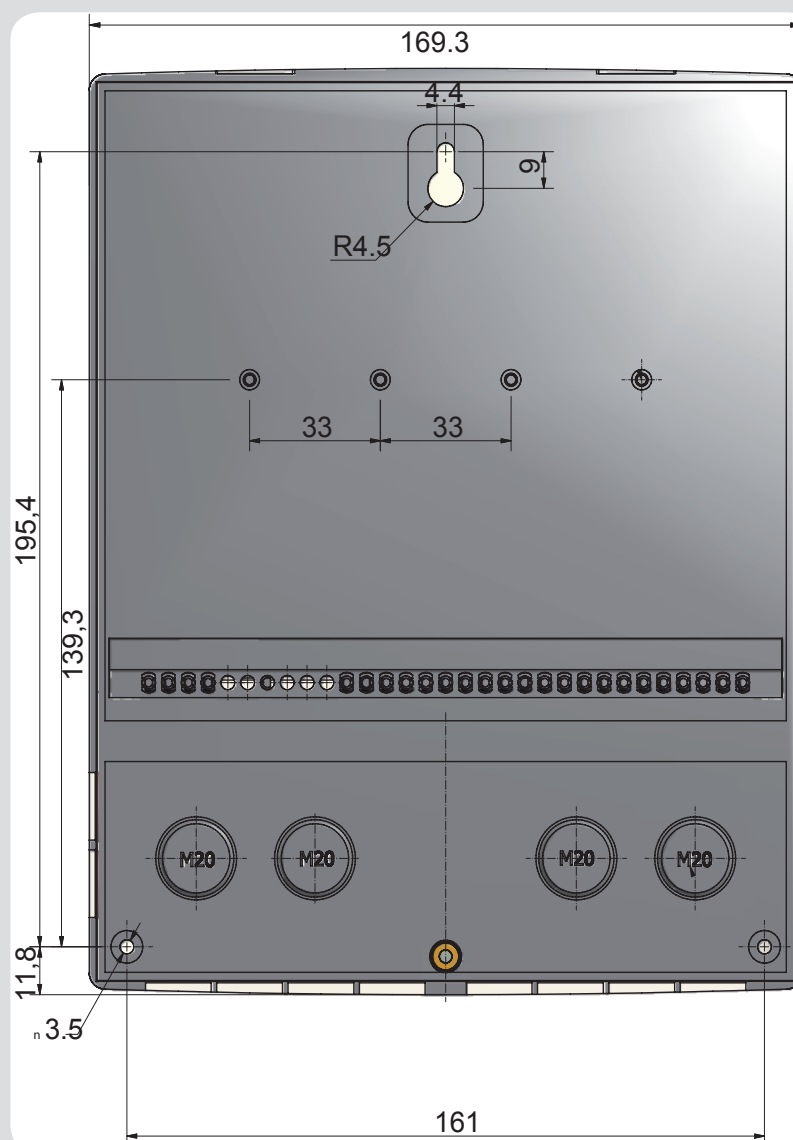



# Installation

## C.2. - Electrical connection

  
**Danger**

Before working on the unit, switch off the power supply and secure it against being switched on again! Check for the absence of power!  
Electrical connections may only be made by a specialist and in compliance with the applicable regulations. Do not use the controller if the housing shows visible damage.

  
**Caution**

Low-voltage cables such as temperature sensor cables must be routed separately from mains voltage cables. Feed temperature sensor cables only into the left-hand side of the unit, and mains voltage cables only into the right-hand side.

  
**Caution**

The customer must provide an all-pole disconnecting device, e.g. a heating emergency switch.

  
**Caution**

The cables being connected to the unit must not be stripped by more than 55mm, and the cable jacket must reach into the housing just to the other side of the strain relief.

  
**Caution**

Controller and VFS sensor have to have the same ground potential. The VFS sensor has a functional earth connector (PELV). The PE-connector of the controller has to be connected to the pipe system near the sensor.

Terminal connection cover

Cover screw

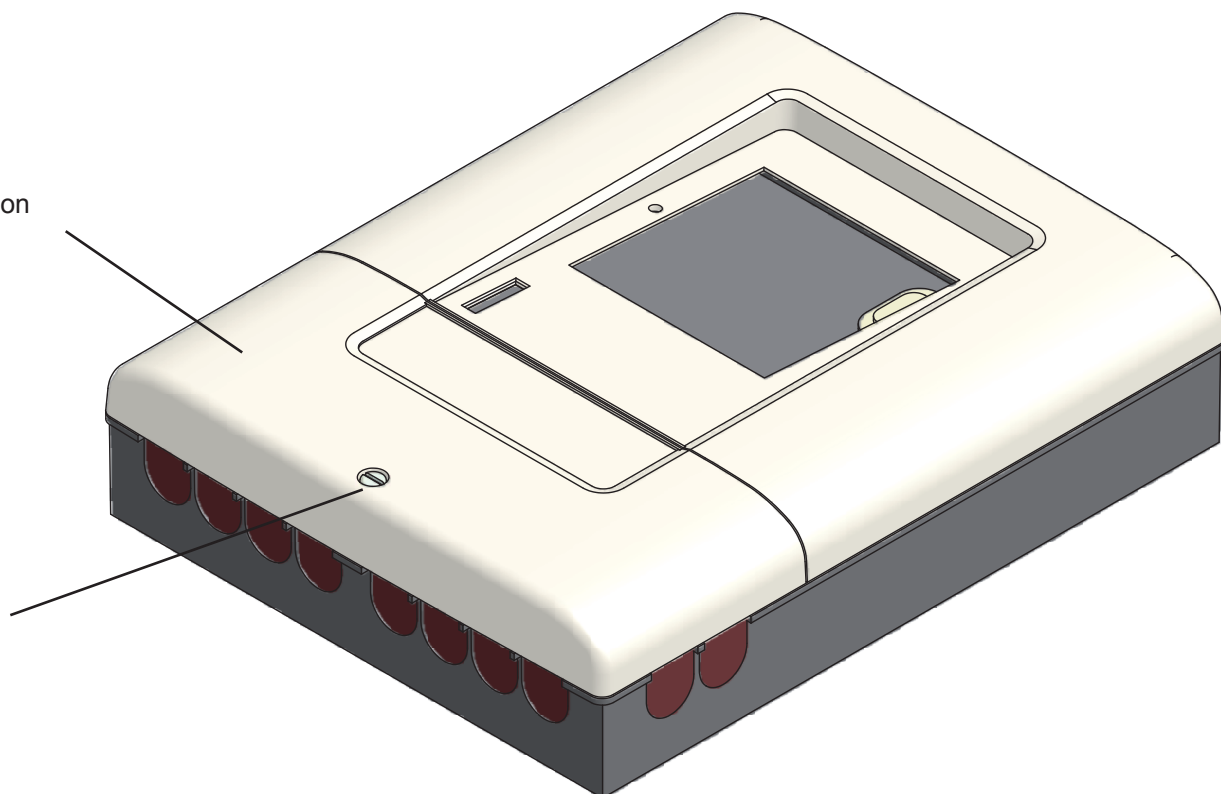

# Installation

## C.2.1.

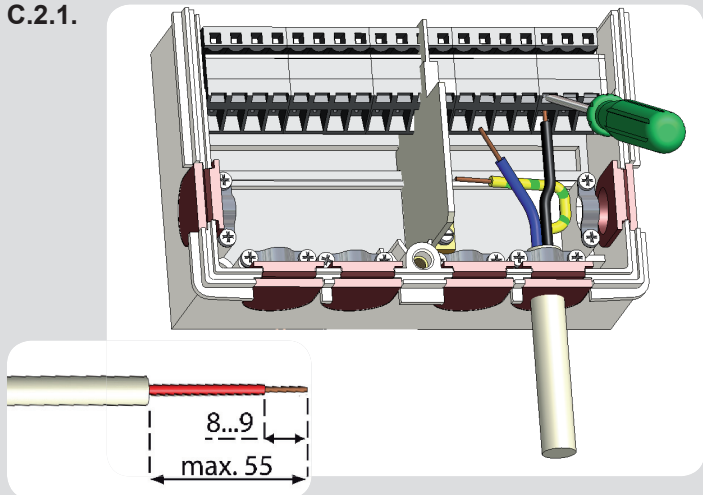

1. Select necessary program/hydraulics (s. „D.3. - Hydraulic variants / Schemes / Systems“ on page 11)
2. Remove terminal connection cover (s. „D.2. - Terminal connection diagram“ on page 10)
3. Strip cables by 55mmmax., insert, fit the strain relief devices, strip the last 8-9mm of the wires (Fig. „C.2.1.“)
4. Open the terminals using a suitable screwdriver (Fig. „C.2.2.“) and make electrical connections on the controller
5. Refit terminal connection cover and fasten screw.
6. Switch on mains voltage and place controller in operation.

## C.2.2.

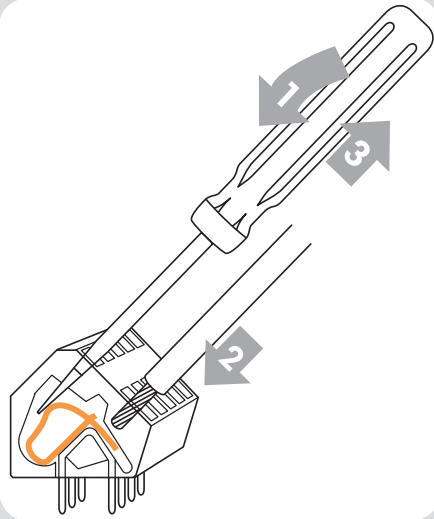

### Instructions for clamps:

1. Insert screw driver into the upper hole. Push the lock clamp inside down. Keep the screw driver in this position.
2. Insert cable into the lower opening.
3. Remove screw driver. The clamp will lock the cable.

## C.3. - Installing the temperature sensors

The controller operates with Pt1000 temperature sensors which are accurate to the degree, thus ensuring optimal control of system functions.



Caution

The temperature sensor cables must be routed separately from mains voltage cables, and must not, for example, be routed in the same cable duct!



Caution

If desired the sensor cables can be extended to a maximum of 30m using a cable with a cross-section of at least 0.75mm<sup>2</sup>. Make sure that there is no contact resistance!  
Position the sensor precisely in the area to be measured!  
Only use immersion, pipe-mounted or flat-mounted sensor suitable for the specific area of application with the appropriate permissible temperature range.



Caution

Connect the VFS sensors with the matching jacks.  
To prevent damage to the Direct Sensors it is highly recommended to install them in to the return.  
When installing the Vortex Flow Sensors (VFS), observe the correct flow direction!



# Installation

## C.4. - RC 21 Remote adjuster with thermostat



The RC21 is an optional accessory and is not supplied by default.  
The SR44 is fully functional without RC21

The remote adjuster with integrated thermostat RC21 provides you with easy to use temperature controlled adjustment of heating from within your living space.

### Settings

The dial is used to parallel translate the heating curve. The flow temperature (still regarding the outdoor temperature) is raised or lowered respectively by your adjustment by max. 5°.

### Sensor

The RC21 contains a temperature sensor which is used by the controller.  
If the settings in the controller allow it, the sensor is used to alter the flow temperature.

The switch changes the operation mode of the controller.

 In **Timer mode** the temperature is controlled according to the set thermostat periods.

 In **Continuous day** mode the set periods are ignored and the temperature is controlled according to the Day time settings.

 In **Continuous night mode** the temperature is usually set to lowest. This setting is best suited for periods of long absence like e.g. holidays.

### Installation

Carefully remove the dial from the casing with a screwdriver.  
Loosen the screw beneath. Remove the bright part of the casing from the black socket.

The RC21 is connected via terminal block to the controller.

Clamp connections:

- 1: Remote adjuster
- 2: Sensor
- 3: Sensor earth

Connection for remote adjuster (grey)  
Connection for sensor (green)  
Connection for sensor earth (white)

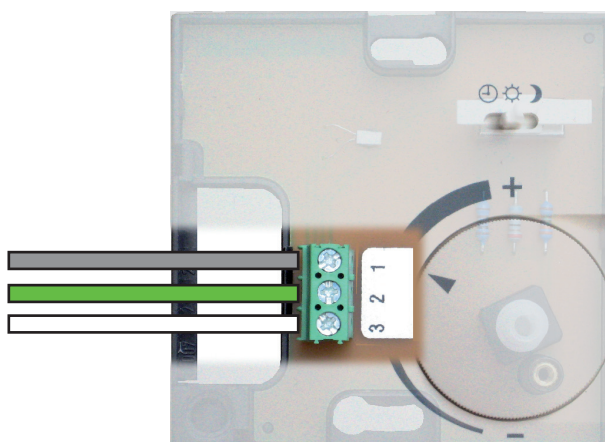

Connect only low voltages!

# Installation

## D.1. - Terminal connection

The mains part of the terminal connection room is covered by a plastic sheet. Make sure that the controller is without voltage before removing it.

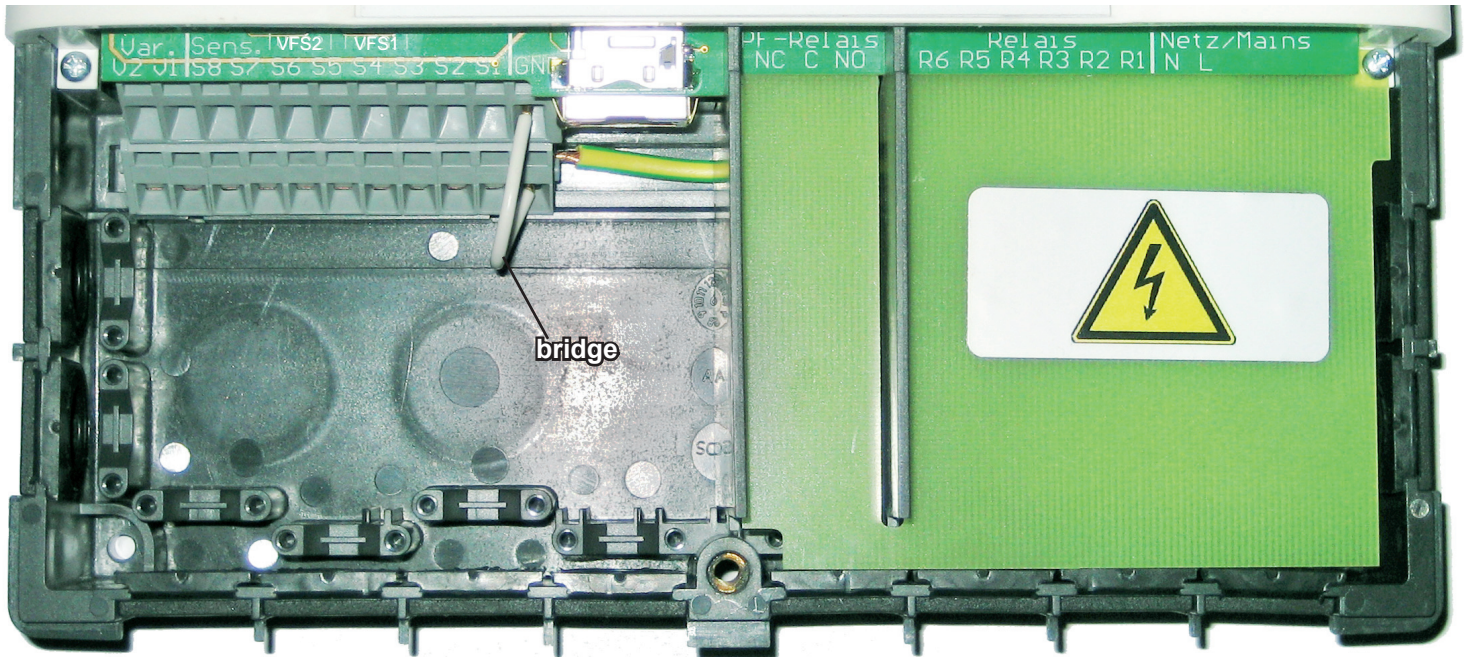

## D.2. - Terminal connection diagram

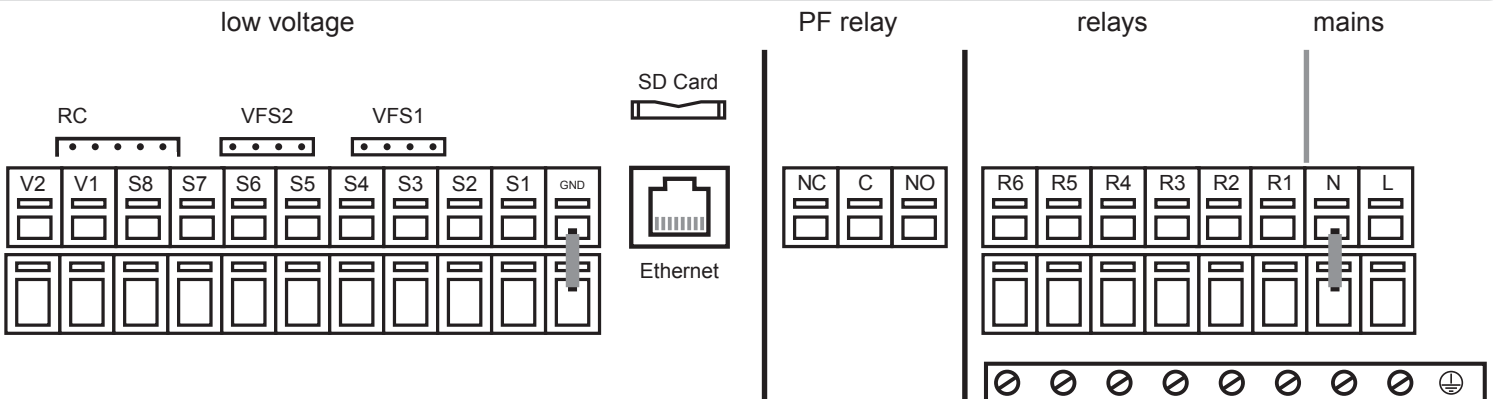

**Caution** max. 12V

**Low voltage** max. 12VAC/DC

Terminal: Connection for:

S1	Sensor 1
S2	Sensor 2
S3	Sensor 3
S4	Sensor 4
S5	Sensor 5
S6	Sensor 6
S7	Sensor 7
S8	Sensor 8
V1	0-10V / PWM
V2	0-10V / PWM
VFS1	Grundfos Direct Sensor
VFS2	Grundfos Direct Sensor
RC	Room Controller

**SD Card Slot**

for Data logging and firmware updates

**Caution**

Make sure that the SD card's orientation is correct! Card must be inserted without pressure. False insertion can damage the card slot!

**Ethernet**  
for LAN network operations

**Potential free Relay**

NO  
Normally open

C  
Common

NC  
Normally closed

**Danger** mains side 230VAC

**Mains voltage** 230VAC 50-60Hz

Terminal: Connection for:

R1	Relay 1
R2	Relay 2
R3	Relay 3
R4	Relay 4
R5	Relay 5
R6	Relay 6
N	Mains neutral conductor N
L	Mains phase conductor L

The PE protective conductor must be connected to the PE metal terminal block!

## D.3. - Hydraulic variants / Schemes / Systems

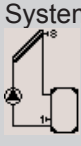
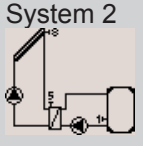
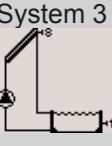
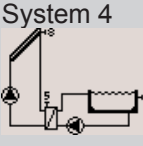
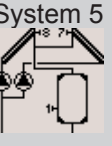
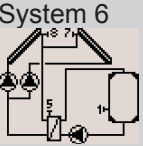
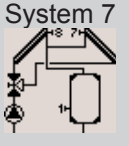
	System 1	System 2	System 3	System 4	System 5	System 6	System 7
							
S1	Storage	Storage	Schwimmbad	Schwimmbad	Storage	Storage	Storage
S2							
S3							
S4							
S5		Heat ex- changer		Heat ex- changer		Heat ex- changer	
S6							
S7					Collector	Collector	Collector
S8	Collector	Collector	Collector	Collector	Collector	Collector	Collector
VFS1							
VFS2							
V1	Optionally selectable for R1	Optionally selectable for R1	Optionally selectable for R1	Optionally selectable for R1	Optionally selectable for R1	Optionally selectable for R1	Optionally selectable for R1
V2	-	Optionally selectable for R2	-	Optionally selectable for R2	Optionally selectable for R2	Optionally selectable for R2	-
R1 (ELR)	<b>Solar pump</b>	<b>Solar pump</b>	<b>Solar pump</b>	<b>Solar pump</b>	<b>Solar pump (Collector at S8)</b>	<b>Solar pump (Collector at S8)</b>	<b>Solar pump</b>
R2 (ELR)	-	<b>Secondary pump</b>	-	<b>Secondary pump</b>	<b>Solar pump Collector S7</b>	<b>Secondary pump</b>	<b>Secondary pump-</b>
R3	-	-	-	-	-	<b>Solar pump Collector S7</b>	<b>Valve Collector S7 / Collector S8 (on = Collec- tor S7)</b>
R4	-	-	-	-	-	-	-
R5	-	-	-	-	-	-	-
R6	-	-	-	-	-	-	-
R7 (Pot. frei)	-	-	-	-	-	-	-

Temperature sensors  
low voltage only

Relay outputs  
230 VA

# Installation

	System 8 	System 9 	System 10 	System 11 	System 12 	System 13 	System 14 	
Temperature sensors low voltage only	S1	Storage	Storage	Storage top	Storage	Storage	Storage	Storage
	S2		Storage	Storage bottom	Storage	Storage	Storage	Storage
	S3							
	S4							
	S5	Heat exchanger					Heat exchanger	Heat exchanger
	S6							
	S7	Collector						
	S8	Collector	Collector	Collector	Collector	Collector	Collector	Collector
	VFS1							
	VFS2							
	V1	Optionally selectable for R1	Optionally selectable for R1	Optionally selectable for R1	Optionally selectable for R1	-	Optionally selectable for R1	Optionally selectable for R1
V2	Optionally selectable for R2	-	-	Optionally selectable for R2	-	Optionally selectable for R2	Optionally selectable for R2	
Relay outputs 230 VA	R1 (ELR)	<b>Solar pump</b>	<b>Solar pump</b>	<b>Solar pump</b>	<b>Pump</b> Storage S1	<b>Solar pump-</b>	<b>Solar pump</b>	<b>Solar pump</b>
	R2 (ELR)	<b>Secondary pump-</b>	-	-	<b>Pump</b> Storage S2	-	<b>Pump</b> Storage S1	<b>Secondary pump</b>
	R3	<b>Valve</b> Collector S7 / Collector S8 (On = Collector S7)	<b>Valve</b> Storage S1/ Storage S2 On=Charge Storage 2	<b>Valve</b> Storage S1/ Storage S2 On=Charge Storage 2	-	<b>Valve</b> Storage S1 (On=Open)	<b>Pump</b> Storage S2	<b>Valve</b> Storage S1 (On = Open)
	R4	-	-	-	-	<b>Valve</b> Storage S2 (On=Open)	-	<b>Valve</b> Storage S2 (On = Open)
	R5	-	-	-	-	-	-	-
	R6	-	-	-	-	-	-	-
	R7 (pot. free)	-	-	-	-	-	-	-

# Installation

	System 15	System 16	System 17	System 18	System 19	System 20	System 21
S1	Storage	Storage	Storage	Storage top	Storage	Storage top	Storage
S2	Storage bottom	Pool	Storage	Storage bottom	Storage	Storage bottom	Storage
S3							
S4							
S5	Heat exchanger	Heat exchanger	Heat exchanger	Heat exchanger			Heat exchanger
S6							
S7					Collector	Collector	Collector
S8	Collector	Collector	Collector	Collector	Collector	Collector	Collector
VFS1							
VFS2							
V1	Optionally selectable for R1	Optionally selectable for R1	Optionally selectable for R1	Optionally selectable for R1	Optionally selectable for R1	Optionally selectable for R1	Optionally selectable for R1
V2	Optionally selectable for R2	Optionally selectable for R2	Optionally selectable for R2	Optionally selectable for R2	Optionally selectable for R2	Optionally selectable for R2	Optionally selectable for R2
R1 (ELR)	<b>Solar pump</b>	<b>Solar pump</b>	<b>Solar pump</b>	<b>Solar pump</b>	<b>Solar pump1</b> Collector S8	<b>Solar pump1</b> Collector S8	<b>Solar pump1</b> Collector S8
R2 (ELR)	<b>Secondary pump</b>	<b>Secondary pump (Pool)</b>	<b>Secondary pump</b>	<b>Secondary pump</b>	<b>Solar pump2</b> (Collector S7)	<b>Solar pump2</b> (Collector S7)	<b>Secondary pump</b>
R3	<b>Valve</b> Storage Top S1 (On= Open)	<b>Valve</b> Storage S2/ Pool S3 (On = Pool charge)	<b>Valve</b> Storage S1/ Storage S2 (On = Charge Storage S2)	<b>Valve</b> Storage Top S1/ Storage Bottom S2 (On = Charge Storage S2 Bottom)	<b>Valve</b> Storage S1/ Storage S2 (On = Charge Storage 2)	<b>Valve</b> Storage Top S1/ Storage Bottom S2 (On = Charge Storage S2 Bottom)	<b>Solar pump2</b> (Collector S7)
R4	<b>Valve</b> Storage Bottom S2 (On= Open)	-	-		-	-	<b>Valve</b> Storage S1/ Storage S2 (On = Charge Storage 2)
R5	-	-	-		-	-	
R6	-	-	-		-	-	
R7 (pot. free)	-	-	-		-	-	

# Installation

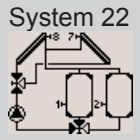
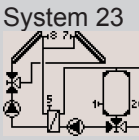
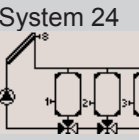
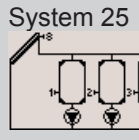
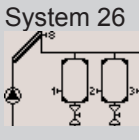
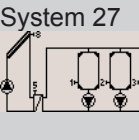
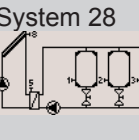
	 System 22	 System 23	 System 24	 System 25	 System 26	 System 27	 System 28	
Temperature sensors low voltage only	S1	Storage	Storage	Storage	Storage	Storage	Storage	
	S2	Storage	Storage	Storage	Storage	Storage	Storage	
	S3			Storage	Storage	Storage	Storage	
	S4							
	S5		Heat exchanger				Heat exchanger	
	S6							
	S7	Collector	Collector					
	S8	Collector	Collector	Collector	Collector	Collector	Collector	
	VFS1							
	VFS2							
	V1	Optionally selectable for R1	Optionally selectable for R1	Optionally selectable for R1	Optionally selectable for R1	Optionally selectable for R1	Optionally selectable for R1	
V2	-	Optionally selectable for R2	-	Optionally selectable for R2	-	Optionally selectable for R2		
Relay outputs 230 V A	R1 (ELR)	<b>Solar pump</b>	<b>Solar pump</b> Collector S8	<b>Solar pump</b>	<b>Pump</b> Storage S1	<b>Solar pump</b>	<b>Solar pump</b>	
	R2 (ELR)	-	<b>Secondary pump</b>	-	<b>Pump</b> Storage S2	-	<b>Secondary pump</b>	
	R3	<b>Valve</b> Collector. (On=Charge Collector S7)	<b>Valve</b> Collector (On=Charge Collector S7)	<b>Valve</b> Storage S1/Storage S2 or S3 (On = Charge Storage S2 or S3)	<b>Pump</b> Storage S3	<b>Valve</b> Storage S1 (On = Open)	<b>Pump</b> Storage S2	<b>Valve</b> Storage S1 (On = Open)
	R4	<b>Valve</b> Storage S1/ Storage S2 (On = Charge Storage 2)	<b>Valve</b> Storage S1/ Storage S2 (On = Charge Storage 2)	<b>Valve</b> Storage S2/ Storage S3 (On = Charge Storage S3)	-	<b>Valve</b> Storage S2 (On = Open)	<b>Pump</b> Storage S3	<b>Valve</b> Storage S2 (On = Open)
	R5	-		-	-	<b>Valve</b> Storage S3 (On = Open)	-	<b>Valve</b> Storage S3 (On = Open)
	R6	-		-	-	-	-	-
	R7 (pot. free)	-		-	-	-	-	-



# Installation

	System 29	System 30	System 31	System 32	System 33	System 34	System 35
S1	Storage top	Storage	Storage	Storage top	Storage Top	Storage	Storage
S2	Storage mitte	Storage 2	Storage	Storage bottom	Storage bottom	Storage	Storage
S3	Storage bottom	Pool	Pool	Pool	Pool	Storage	Storage
S4							
S5	Heat exchanger		Heat exchanger	Heat exchanger	Heat exchanger		Heat exchanger
S6				Heat exchanger	Heat exchanger		
S7						Collector	Collector
S8	Collector	Collector	Collector	Collector	Collector	Collector	Collector
VFS1							
VFS2							
V1	Optionally selectable for R1	Optionally selectable for R1	Optionally selectable for R1	Optionally selectable for R1	Optionally selectable for R1	Optionally selectable for R1	Optionally selectable for R1
V2	Optionally selectable for R2	Optionally selectable for R2	Optionally selectable for R2	Optionally selectable for R2	Optionally selectable for R2	Optionally selectable for R2	Optionally selectable for R2
R1 (ELR)	<b>Solar pump</b>	<b>Solar pump</b>	<b>Solar pump</b>	<b>Solar pump</b>	<b>Solar pump</b>	<b>Solar pump1</b> Collector an S8	<b>Solar pump1</b> Collector an S8
R2 (ELR)	<b>Secondary pump</b>	<b>Pool pump</b>	<b>Pool pump</b>	<b>Secondary pump</b> (in Storage circuit)	<b>Secondary pump</b> (in Storage circuit)	<b>Solar pump2</b> Collector an S7	<b>Solar pump2</b> Collector an S7
R3	<b>Valve</b> Storage Top S1 (On = Open)	<b>Valve</b> Storage S1 and Storage S2 (On = Charge Storage S2)	<b>Valve</b> Storage S1 (On = Open)	<b>Valve</b> Storage S1 and S2 / Pool (On = Charge Pool)	<b>Valve</b> Storage Top S1 (On = Open)	<b>Valve</b> Storage S1/ Storage S2 and S3 (On = Charge Storage S2 und S3)	<b>Secondary pump</b>
R4	<b>Valve</b> Storage middle S2 (On = Open)	<b>Valve</b> Storage S2/ Pool S3 (On = Charge Pool S3)	<b>Valve</b> Storage S2 (On = Open)	<b>Pool pump</b>	<b>Pool pump</b>	<b>Valve</b> Storage S2/ Storage S3 (On = Charge Storage S3)	<b>Valve</b> Storage S1/ other storages (On = Charge other storages)
R5	<b>Valve</b> Storage Bottom S3 (On = Open)	-	<b>Valve</b> Pool S3 (On = Open)	<b>Valve</b> Storage Top S1/ Storage Bottom S2 (On = Charge Storage Top S1)	<b>Valve</b> Storage Bottom S2 (On = Open)	-	<b>Valve</b> Storage S2/ Storage S3 (On = Charge Storage S3)
R6	-	-	-	-	-	-	-
R7 (pot. free)	-	-	-	-	-	-	-

# Installation

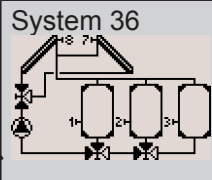
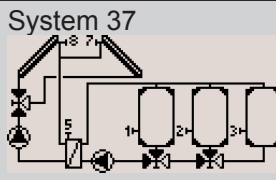
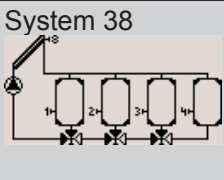
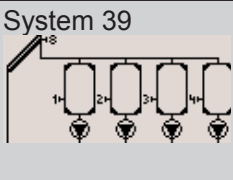
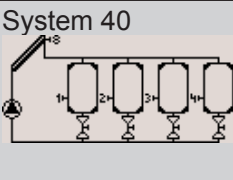
System	System 36	System 37	System 38	System 39	System 40	
Anschluss						
<b>Temperature sensors</b> low voltage only	S1	Storage	Storage	Storage	Storage	
	S2	Storage	Storage	Storage	Storage	
	S3	Storage	Storage	Storage	Storage	
	S4			Storage	Storage	
	S5					
	S6					
	S7	Collector	Collector			
	S8	Collector	Collector	Collector	Collector	Collector
	VFS1					
	VFS2					
	V1	Optionally selectable for R1	Optionally selectable for R1	Optionally selectable for R1	Optionally selectable for R1	Optionally selectable for R1
	V2		Optionally selectable for R2		Optionally selectable for R2	-
<b>Relay outputs</b> 230 VA	R1 (ELR)	<b>Solar pump1</b> Collector an S8	<b>Solar pump1</b> Collector an S8	<b>Solar pump1</b> Collector an S8	<b>Pump</b> Storage S1	<b>Solar pump</b>
	R2 (ELR)		<b>Secondary pump</b>		<b>Pump</b> Storage S2	-
	R3	<b>Valve</b> Collector (On=Charge Collector S7)	<b>Valve</b> Collector (On=Charge Collector S7)	<b>Valve</b> Storage S1/ other Storage (On = Charge other Storages)	<b>Pump</b> Storage S3	<b>Valve</b> Storage S1 (On = Open)
	R4	<b>Valve</b> Storage S1/ other Storage (On = Charge other Storages)	<b>Valve</b> Storage S1/ other Storage (On = Charge other Storages)	<b>Valve</b> Storage S2/ other Storage (On = Charge other Storages)	<b>Pump</b> Storage S4	<b>Valve</b> Storage S2 (On = Open)
	R5	<b>Valve</b> Storage S2/ Storage S3 (On = Charge Storage S3)	<b>Valve</b> Storage S2/ Storage S3 (On = Charge Storage S3)	<b>Valve</b> Storage S3/ Storage S4 (On = Charge Storage S4)	-	<b>Valve</b> Storage S3 (On = Open)
	R6			-		<b>Valve</b> Storage S4 (On = Open)-
	R7 (pot. free)					

# Installation

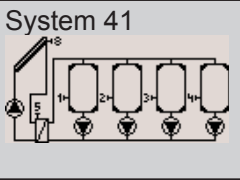
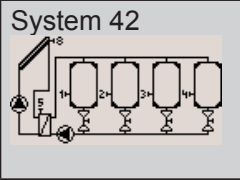
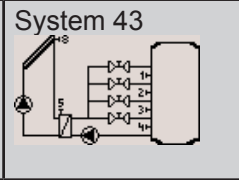
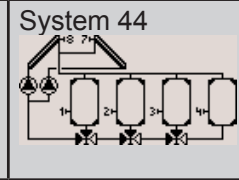
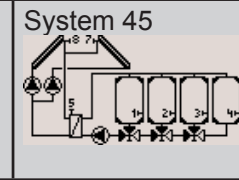
Anschluss	System 41 	System 42 	System 43 	System 44 	System 45 
S1	Storage	Storage	Storage top	Storage	Storage
S2	Storage	Storage	Storage middle/top	Storage	Storage
S3	Storage	Storage	Storage middle/bottom	Storage	Storage
S4	Storage	Storage	Storage bottom	Storage	Storage
S5	Heat exchanger	Heat exchanger	Heat exchanger		Heat exchanger
S6					
S7				Collector	Collector
S8	Collector	Collector	Collector	Collector	Collector
VFS1					
VFS2					
V1	Optionally selectable for R1	Optionally selectable for R1	Optionally selectable for R1	Optionally selectable for R1	Optionally selectable for R1
V2	Optionally selectable for R2	Optionally selectable for R2	Optionally selectable for R2	Optionally selectable for R2	Optionally selectable for R2
R1 (ELR)	<b>Solar pump</b>	<b>Solar pump</b>	<b>Solar pump</b>	<b>Solar pump1</b> Collector an S8	<b>Solar pump1</b> Collector an S8
R2 (ELR)	<b>Pump</b> Storage S1	<b>Secondary pump</b>	<b>Secondary pump</b>	<b>Solar pump2</b> Collector at S7	<b>Secondary pump</b>
R3	<b>Pump</b> Storage S2	<b>Valve</b> Storage S1 (On = Open)	<b>Valve</b> Storage Top S1 (On = Open)	<b>Valve</b> Storage S1/ other Storage (On = Charge other Storage)	<b>Solar pump2</b> Collector an S7
R4	<b>Pump</b> Storage S3	<b>Valve</b> Storage S2 (On = Open)	<b>Valve</b> Storage Middle Top S2 (On = Open)	<b>Valve</b> Storage S2/ other Storage (On = Charge other storages)	<b>Valve</b> Storage S1/ other Storage (On = Charge other storages)
R5	<b>Pump</b> Storage S4	<b>Valve</b> Storage S3 (On = Open)	<b>Valve</b> Storage Middle Bottom S3 (On = Open)	<b>Valve</b> Storage S3/ Storage S4 (On = Charge storage S4)	<b>Valve</b> Storage S2/ other Storage (On = Charge other storages)
R6		<b>Valve</b> Storage S4 (Ein = Open)-	<b>Valve</b> Storage Bottom S4 (On = Open)		<b>Valve</b> Storage S3/ other Storage (On = Charge other storage)
R7 (pot. free)					

# Installation

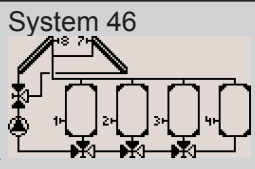
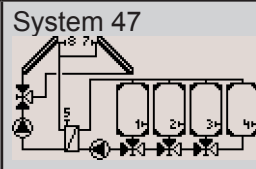
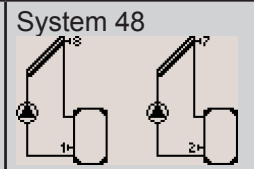
Anschluss	System 46 	System 47 	System 48 	
<b>Temperature sensors</b> low voltage only	S1	Storage	Storage	Storage 1
	S2	Storage	Storage	Storage 2
	S3	Storage	Storage	
	S4	Storage	Storage	
	S5			
	S6			
	S7	Collector	Collector	Collector 1
	S8	Collector	Collector	Collector 2
	VFS1			
	VFS2			
	V1	Optionally selectable for R1	Optionally selectable for R1	Optionally selectable for R1
	V2		Optionally selectable for R2	Optionally selectable for R2
<b>Relay outputs</b> 230 VA	R1 (ELR)	<b>Solar pump</b>	<b>Solar pump</b>	<b>Solar pump1</b> Collector an S8
	R2 (ELR)		<b>Secondary pump</b>	<b>Solar pump2</b> Collector an S7
	R3	<b>Valve</b> Collector (On=Charge Collector S7)	<b>Valve</b> Collector (On=Charge Collector S7)	
	R4	<b>Valve</b> Storage S1/ other Storage (On = Charge other storages)	<b>Valve</b> Storage S1/ other Storage (On = Charge other storages)	
	R5	<b>Valve</b> Storage S2/ other Storage (On = Charge other storages)	<b>Valve</b> Storage S2/ other Storage (On = Charge other storages)	
	R6	<b>Valve</b> Storage S3/ Storage S4 (On = Charge storage S4)	<b>Valve</b> Storage S3/ Storage S4 (On = Charge storage S4)	
	R7 (pot. free)			

## E.1. - Display and input

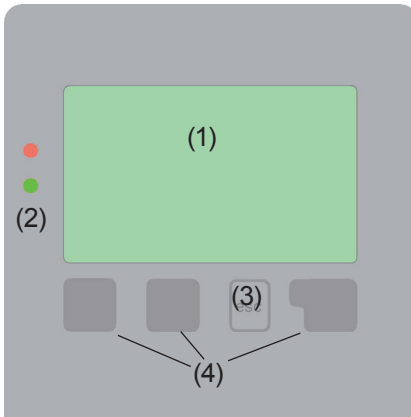

The display (1), with its extensive text and graphics mode, is almost self-explanatory, allowing easy operation of the controller.











To change from the overview to the settings menu, press the „esc“ key.

The green status LED (2) lights up when a relay is active, the red LED blinks when an error occurs.

Inputs are made with 4 buttons (3+4), which functions change context sensitive. The „esc“ key (3) is always used to cancel or exit a menu.

If applicable there will be a request for confirmation as to whether the changes which have been made should be saved.

Examples of display symbols:

-  Pump (rotates in operation)
-  Valve (direction of flow in black)
-  Collector
-  Storage
-  Pool
-  Temperature sensor
-  Heat exchanger
-  Load pause (see Load time)
-  Warning / error message
-  New information available
-  Logging is active

More symbols can be found in the chapter „Special functions“

The function of each of the other three keys (4) is shown in the display line directly above the keys; the right-hand key is generally has a confirmation and selection function.

Examples of key functions:

- +/- = enlarge/shrink values
- ▼/▲ = scroll menu down/up
- yes/no = approve/reject
- Info = additional information
- Back = to previous screen
- ok = confirm selection
- Confirm = confirm setting

## E.2 Commissioning help

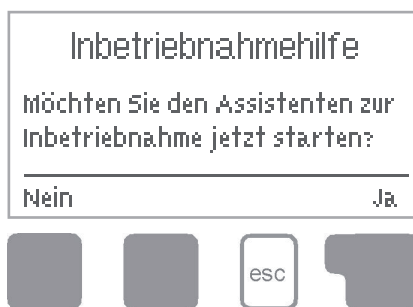

The first time the controller is turned on and after the language and time are set, a query appears as to whether you want to parametrise the controller using the commissioning help or not. The commissioning help can also be terminated or called up again at any time in the special functions menu. The commissioning help guides you through the necessary basic settings in the correct order, and provides brief descriptions of each parameter in the display.

Pressing the “esc” key takes you back to the previous value so you can look at the selected setting again or adjust it if desired. Pressing the “esc” more than once takes you back step by step to the selection mode, thus cancelling the commissioning help. Finally, menu „3.2. - Manual“ on page 22 should be used to test

the switch outputs with the consumers connected, and to check the sensor values for plausibility. Then switch on automatic mode.



Observe the explanations for the the individual parameters on the following pages, and check whether further settings are necessary for your application.

## E.3 Free commissioning

If you decide not to use the commissioning help, you should make the necessary settings in the following sequence:

- Menu 9. Language, page 44
- Menu 6.23 Time and Date, page 42
- Menu 6.1 Programmwahl, page 27
- Menu 4. Settings, all values, page 23
- Menu 5. Protective functions, if necessary, page 25
- Menu 6. Special functions, if necessary, page 27

Finally, menu „3.2. - Manual“ on page 22 should be used to test the switch outputs with the consumers connected, and to check the sensor values for plausibility. Then switch on automatic mode.



**Caution** Observe the explanations for the the individual parameters on the following pages, and check whether further settings are necessary for your application.

## E.4 Menu sequence and menu structure

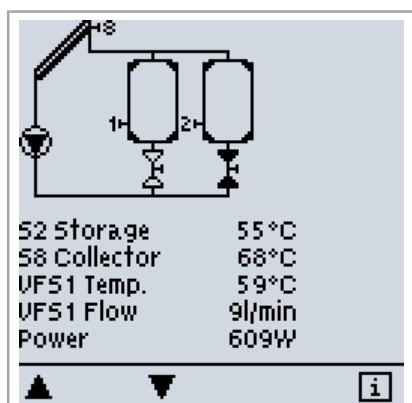

The graphics or overview mode appears when no key has been press for 2 minutes, or when the main menu is exited by pressing “esc”.  
The up and down buttons are used to scroll through the list of sensors and relays

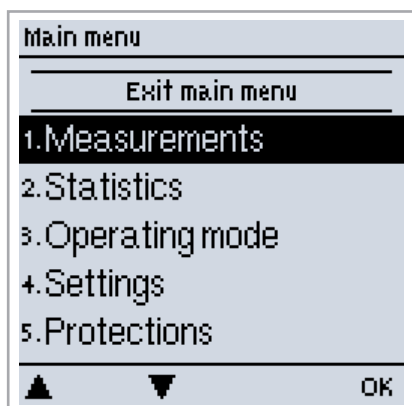

You can enter the Main menu by pressing the „esc“ key. The following menus are available:

1. Measurements

Current temperature values with explanations

2. Statistics

Function control of the system with operating hours, etc

3. Operating mode

Automatic mode, manual mode or switch unit off

4. Settings

Set parameters needed for normal operation

5. Protections

Solar and frost protection, recooling, anti-seizing protection

6. Special functions

Program selection, sensor calibration, clock, additional sensor, etc.

7. Menu lock

Against unintentional setting changes at critical points

8. Service Data

For diagnosis in the event of an error

9. Language

Language selection



# Measurement values

## 1. - Measurement values

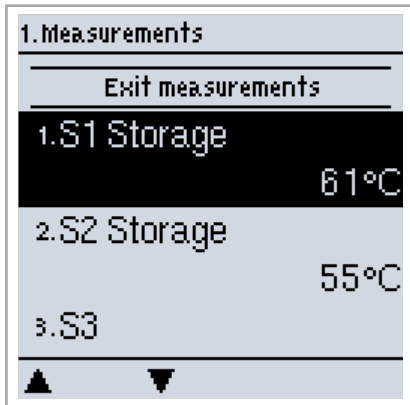

The menu “1. Measurement values” serves to display the currently measured temperatures.

The menu is closed by pressing “esc” or selecting “Exit measurement values”.

Selecting “Overview” or “esc” exits the Info mode.



Caution

If “Error” appears on the display instead of the measurement value, then there may be a defective or incorrect temperature sensor. If the cables are too long or the sensors are not placed optimally, the result may be small deviations in the measurement values. In this case the display values can be compensated for by making entries on the controller. Follow the instructions under „6.19. - Sensor calibration“ on page 41.

What measurement values are displayed depends on the selected program, the connected sensors and the specific device design.

# Statistics

## 2. - Statistics

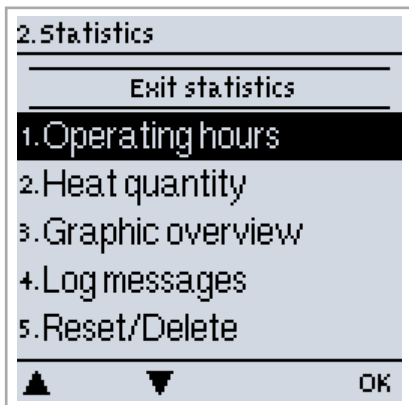

The menu “2. Statistics” is used for function control and long-term monitoring of the system.

The menu is closed by pressing “esc” or selecting “Exit statistics”.



Caution

For analysis of the system data it is essential for the time to be set accurately on the controller. Please note that the clock does not continue to run if the mains voltage is interrupted, and must therefore be reset. Improper operation or an incorrect time may result in data being deleted, recorded incorrectly or overwritten.

The manufacturer accepts no liability for the recorded data!

### 2.1. - Operating hours

Display of operating hours of the solar pump connected to the controller; various time ranges (day-year) are available.

### 2.2. - Heat output

Display of the heat output of the system.

### 2.3. - Graphic overview

This provides a clearly-organised display of the data listed under 2.1-2.2 as a bar graph. Various time ranges are available for comparison. The two left-hand keys can be used to page through the data.

### 2.4. - Message log

Display of the last 20 events occurring in the system with indication of date and time.

### 2.5. - Reset/clear

Resetting and deleting the individual analyses. The function “All statistics” clears all analyses but not the error messages.

## 3. - Operating modes

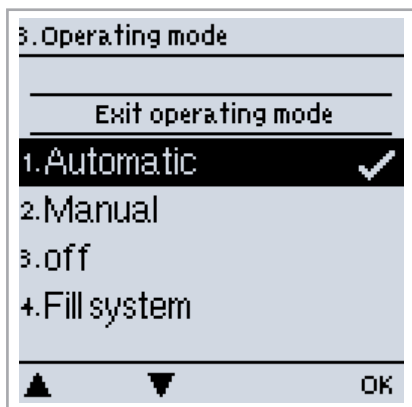

In menu “3. Operating modes” the controller can either be placed in automatic mode, switched off, or placed in a manual operating mode.

The menu is closed by pressing “esc” or selecting “Exit operating modes”.

### 3.1. - Automatic

Automatic mode is the normal operating mode of the controller. Only automatic mode provides proper controller function taking into account the current temperatures and the parameters that have been set! After an interruption of the mains voltage the controller automatically returns to the last operating mode selected!

### 3.2. - Manual

The relay and thus the connected consumer are switched on and off by pressing a key, with no regard to the current temperatures and the parameters which have been set. The measured temperatures are also shown to provide an overview and function control.



When operating mode “Manual” is activated, the current temperatures and the selected parameters are no longer considered. There is a danger of scalding or serious damage to the system. The operating mode “Manual” may only be used by specialists for brief function tests or during commissioning!

### 3.3. - Off



When the operating mode “Off” is activated, all controller functions are switched off. This can lead, for example, to overheating on the solar collector or other system components. The measured temperatures are still displayed to provide an overview.

### 3.4. - Fill system



This special operating mode is intended only for the filling procedure for a special “Drain Master System” with a fill level contact parallel to collector sensor S1. The instructions on the display must be followed when filling the system. Be sure to terminate the function when finished!

## 4. - Settings

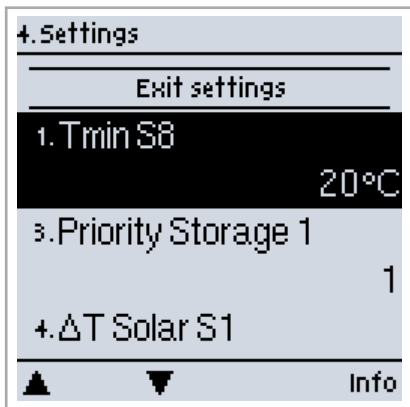

The necessary basic settings required for the control function are made in menu "5. Settings".



This does not under any circumstances replace the safety facilities to be provided by the customer!

The menu is closed by pressing "esc" or selecting "Exit settings".



The following pages contain generally valid descriptions for the settings. Enumerations may vary .

### 4.1. - Tmin S (X)

#### Enable/start temperature at sensor X:

If this value is exceeded at the applicable sensor X and the other conditions are also met, then the controller switches on the associated pump and/or valve. If the temperature at the sensor drops below this value by 5°C, then the pump and/or the valve are switched off again.

*Settings range : 0°C to 99 °C / Default setting: 20°C*

### 4.2. - Tmax S (X)

#### Switch-off temperature at sensor X

If this value is exceeded at the applicable sensor X, the controller switches the associated pump and/or valve off. If the temperature falls below this value again and the other conditions are also met, then the controller switches the pump and/or valve on again.

*Settings range: 0°C to 99 °C / Default setting: 60°C*



Temperature values which are set too high can lead to scalding or damage to the system. Scalding protection must be provided by the customer!

### 4.3. - Tmax SB

#### Switch-off temperature at pool sensor

If this value is exceeded at the applicable sensor, the controller switches the associated pump and/or valve off. If the temperature falls below this value again and the other conditions are also met, then the controller switches the pump and/or valve on again.

*Settings range: 0°C to 50°C / Default setting: 30°C*



Temperature values which are set too high can lead to scalding or damage to the system. Scalding protection must be provided by the customer!

### 4.4. - Δ T Solar S (X)

#### Switch-on/switch-off temperature difference for sensor X :

If this temperature difference between the reference sensors is exceeded and the other conditions are also met, then the controller switches the applicable relay on. When the temperature drops to ΔT Off, then the relay is switched off.

*Settings range: ΔT On from 6°C to 20°C / ΔT Off from 2°C to ΔTOn-1°C*

*Default setting: ΔT 10°C / ΔT-Off 3°C (in systems with external heat exchanger: ΔT 15°C / ΔT-Off 7°C)*



If the set temperature difference is too small, this may result in ineffective operation, depending on the system and sensor positions. Special switching conditions apply for speed control (see „6.2. - Speed control“ on page 27)!

## 4.5. - Priority S(X)

### Priority of Storages X

This determines the order, in which the storages are charged.

*Settings range: 1-4*

## 4.6. - T-priority

### Temperature threshold for absolute priority

In systems with multiple storage tanks, charging of the lower-priority storage tank will never take place until this set temperature setpoint at the storage tank sensor of the higher-priority storage tank is exceeded.

*Setting range: from 0°C to 90°C/default setting: 40°C*

## 4.7. - Loading time

### Interruption of charging into the lower priority storage tank

The charging of the lower-priority storage tank is interrupted after the settable time in order to check whether the collector has reached a temperature level that allows charging in the higher-priority storage tank. If so, the priority storage tank is charged. If not, the increase is measured (see „4.8. - Increase“), to check if charging of the priority storage tank will be possible shortly.

*Setting range: from 1 to 90 minutes/default setting: 20 minutes*

## 4.8. - Increase

### Extension of the charging pause due to temperature increase in the collector

For precise setting of the charging priorities for systems with multiple storage tanks, the necessary temperature increase of the collector at which the interruption of the charging into the lower-priority storage tank is extended by one minute is set here. The interruption is extended because the temperature increase of the collector is expected to enable charging in the higher-priority storage tank soon.

As soon as  $\Delta T$  conditions are met, the priority storage tank is charged. If the rise in temperature falls below the set value, then the charging of the lower-priority storage tank is enabled again.

*Setting range: from 1°C to 10°C/default setting: 3°C*

# Protections

## 5. - Protections / Protective functions

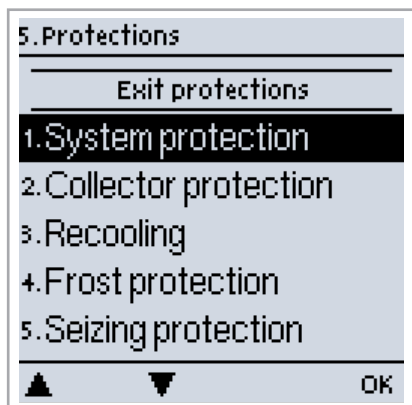

Menu „6. - Protective functions“ can be used to activate and set various protective functions.



This does not under any circumstances replace the safety facilities to be provided by the customer!

The menu is closed by pressing “esc” or selecting “Exit”.

### 5.1. - System protection

#### Highest Priority Protection

System protection prevents overheating of system components by automatic shutdown of the solar pump. If “SProt Ton” is exceeded at the collector, the pump is switched off and stays off. The pump is activated again when the temperature drops below “SProt TOff”.

*System protection - Settings range: ON / OFF / Default setting: On*

*SP T on - Settings range: 60 °C to 150 °C / Default setting: 120 °C*

*SP T off - Settings range: 50 °C to T on minus 5 °C / Default setting: 115 °C*



When system protection is on, the temperature in the idle collector will be very high, thus the pressure in the system will rise and can damage your system.

Pay close attention to the instructions of the system manufacturer.

### 5.2. - Collector protection

Collector protection prevents overheating of the collector. The pump is switched on to transfer heat from the collector to the storage tank.

If “CP Ton” is exceeded at the collector sensor, the pump is switched on until the temperature reaches “CP Toff” or the temperature “CP Tmax storage” is exceeded in the storage.

*Collectorprotection - Settings range: On / Off / Default setting: Off*

*CP T on - Settings range: 60°C to 150°C / Default setting: 110°C*

*CP T off - Settings range: 50°C to T on minus 5°C / Default setting: 100°C*

*CP Storage S(x) Max - Settings range: 0°C to 140°C / Default setting: 90°C*



When collector protection is active, the storage is heated up to „CP Storage S(x) Max“ beyond Tmax S2 (see „4.2. - Tmax S (X)“ on page 23) which can result in scalding and system damage.



System protection has a higher priority than collector protection. Even when the switch on conditions for collector protection are present, the solar pump will be switched off when SP T on is reached.

### 5.3. - Recooling

In hydraulic systems with solar when the recooling function is activated excess energy from the storage tank is fed back into the collector. This only takes place if the temperature in the storage tank is higher than the value “Recool Tsetpoint” and the collector is at least 20°C cooler than the storage tank and before the storage tank temperature has dropped below the value “Recool Tsetpoint” (Hysteresis 10°C).

In systems with two storage tanks the setting applies to both storage tanks.

*Recooling - Settings range: On, Off / Default setting: Off*

*Rückkühl Tsoll - Settings range: 0°C to 99°C / Default setting: 70°C*



Energy is lost via the collector when Recooling is active! Recooling should only be activated as exception, when little or no heat is used, e.g. when the residents are on vacations.

## 5.4. - Frostschutz

A two-stage frost protection function can be activated. In stage 1 the controller switches the pump on for 1 minute every hour if the collector temperature drops below the set value "Frost stage 1".

If the collector temperature drops further to the set value "Frost stage 2" the controller switches the pump on continuously.

If the collector temperature then exceeds the value "Frost stage 2" by 2°C, then the pump switches off again.

*Frost protection setting range: on, off/default setting: off*

*Frost stage 1 setting range: from -25°C to 10°C or off/default setting: 7°C*

*Frost stage 2 setting range: from -25°C to 8°C (must be lower than stage 1) / default setting: 5°C*



This function causes energy to be lost via the collector! It is normally not activated for solar systems with antifreeze. Observe the operating instructions for the other system components!

## 5.5. - Seizing protection

If the seizing protection is activated, the controller switches the relay in question and the connected consumer on every day at 12:00 (setting "daily") or weekly on Sundays at 12:00 (setting "weekly") for 5 seconds in order to prevent the pump and/or the valve from sticking after an extended stationary period.

*Setting range: daily, weekly, off/default setting: Off*

## 5.6. - Collector alarm

If this temperature is exceeded at the collector sensor when the solar pump is on a warning or error message is triggered. A warning message is shown in the display.

*Collector alarm - Settings range: Off, On / Default setting: Off*

*Collector alarm - Settings range: 60 to 299 / Default setting: 115°C*

*Delay - Settings range: 1 to 60 Minuten / Default setting: 1*



## 6. - Special functions



Menu "7. Special functions" is used to set basic items and expanded functions.



Other than the time all settings may only be made by a specialist.

The menu is closed by pressing "esc" or selecting "Exit special functions".



The enumeration of the menus may vary from system to system.

### 6.1. - Program selection

The suitable hydraulic variant for the specific application is selected and set here (see „D.3. - Hydraulic variants / Schemes / Systems“ on page 11). The associated diagram is displayed.

*Settings range: 1-48 / Default setting: 1*



Normally the program selection is made only once during initial commissioning by the specialist. Incorrect program selection can lead to unpredictable errors.

### 6.2. - Speed control

With speed control the SR44 makes it possible to vary the speed of connected pumps.



This function should only be activated by a specialist. Depending on the pump and pump stage used, the minimum speed should not be set too low, because otherwise the pump or the system may be damaged. The information provided by the relevant manufacturer must also be observed! If in doubt, the min. speed and the pump stage should generally be set to high rather than too low.

#### 6.2.1. - Variant

The following speed variants are available here:

**Off:** There is no speed control. The connected pump is only switched on or off with full speed.

**Variant V1:** After the purging time the controller switches to the set max. speed. If the temperature difference  $\Delta T$  between the reference sensors (collector and storage tank) is less than the set value, then the speed is decreased by one stage after the control time elapses. If the temperature difference between the reference sensors is greater than the set value, then the speed is increased by one stage after the control time elapses. If the controller has adjusted the speed of the pump down to the smallest stage and the  $\Delta T$  between the reference sensors is  $\Delta T$  off, the pump is switched off.

**Variant V2:** After the purging time the controller switches to the set min. speed. If the temperature difference  $\Delta T$  between the reference sensors (collector and storage tank) is greater than the set value, then the speed is increased by one stage after the control time elapses. If the temperature difference  $\Delta T$  between the reference sensors is below the set value, then the speed is decreased by one stage after the control time elapses. If the controller has adjusted the speed of the pump down to the smallest stage and the  $\Delta T$  between the reference sensors is  $T\Delta$ off, the pump is switched off.

**Variant V3:** After the purging time the controller switches to the set min. speed. If the temperature at the reference sensor (collector) is greater than the setpoint to be set subsequently, then the speed is increased by one stage after the control time expires. If the temperature at the reference sensor (collector) is less than the setpoint to be set subsequently, then the speed is decreased by one stage after the control time expires.

*Setting range: V1,V2,V3, off/default setting: off*

**Variant V4:**

When the primary storage is loaded, speed control works as in V3.

When the secondary storage is loaded, speed control works as in V2.

*Settings range: V1,V2,V3, Off / Default: Off*

#### 6.2.2. - Type of pump

The type of speed controlled pump must be entered here.

**Standard:** Speed control for standard pumps.

**0-10V:** Speed control of e.g. High efficiency pumps by 0-10V signal.

**PWM:** Speed control of e.g. High efficiency pumps by PWM signal.

# Special functions

## Speed control

### 6.2.3. - Pump menu

This menu contains the settings for 0-10V or PWM pump.



Caution

When selecting this submenu, you may be prompted to save the speed control settings.

#### 6.2.3.1. - Pump

In this menu, preconfigured profiles for various pumps can be selected. Please note that individual settings are still possible even when a profile has been selected.

#### 6.2.3.2. - Output Signal

This menu determines the type of pump used: Solar pumps perform at their highest power when the signal is also maxed, heating pump on the other hand are set to highest power wenn the control signal is at the lowest. Solar = normal, heating = Inverted.

*Settings range: Normal, Inverted / Default setting: Normal*

#### 6.2.3.3. - PWM off

This signal is put out when the pump is switched off (Pumps that can detect cable break need a minimum signal).

*Settings range: (Solar:) 0 to 50% / Default setting: 0% - (Heating:) 50% to 100% / Default setting: 100%*

#### 6.2.3.4. - PWM on

This signal is needed to turn the pump on at minimum speed.

*Settings range: (Solar:) 0 to 50% / Default setting: 10% - (Heating:) 50% to 100% / Default setting: 90%*

#### 6.2.3.5. - PWM Max

This determines the the output signal for the highest speed of the pump, that is used e.g. during purging or manual operation.

*Settings range: (Solar:) 50 to 100% / Default setting: 100% - (Heating:) 0% to 50% / Default setting: 0%*

#### 6.2.3.6. - 0-10V off

This voltage is put out when the pump is turned off (Pumps that can detect cable break need a minimum voltage).

*Settings range: (Solar:) 0,0 to 5,0 V / Default setting: 1,0 V - (Heating:) 5,0 to 0,0 V / Default setting: 4 ,0 V*

#### 6.2.3.7. - 0-10V on

This voltage is needed to turn the pump on at minimum speed.

*Settings range: (Solar:) 0,0 to 5,0 V / Default setting: 1,0 V - (Heating:) 5,0 to 10,0 V / Default setting: 9,0 V*

#### 6.2.3.8. - 0-10V Max

This determines the output voltage for the highest speed of the pump, that is used e.g. during purging or manual operation

*Settings range: (Solar:) 5,0 to 10,0 V / Default setting: 10,0 V - (Heating:) 0,0 to 5,0 V / Default setting: 0,0 V*

#### 6.2.3.9. - Speed when „On“

This menu determines the calculated and displayed speed of the pump. If e.g. 30% is set here and the signal set in „PWM on/0-10V on“ is put out, 30% speed is displayed. When the signal set in „PWM max/0-10V max“ is put out, 100% speed is displayed. Everything in between is calculated accordingly.

*Settings range: 10 to 90 % / Default setting: 30 %*



Caution

This function has no influence on the regulation, but changes only the speed displayed.

#### 6.2.3.10. - Show signal

Displays the set signal in text and a graphical diagram.

# Special functions

## 6.2.3a Example for pump settings

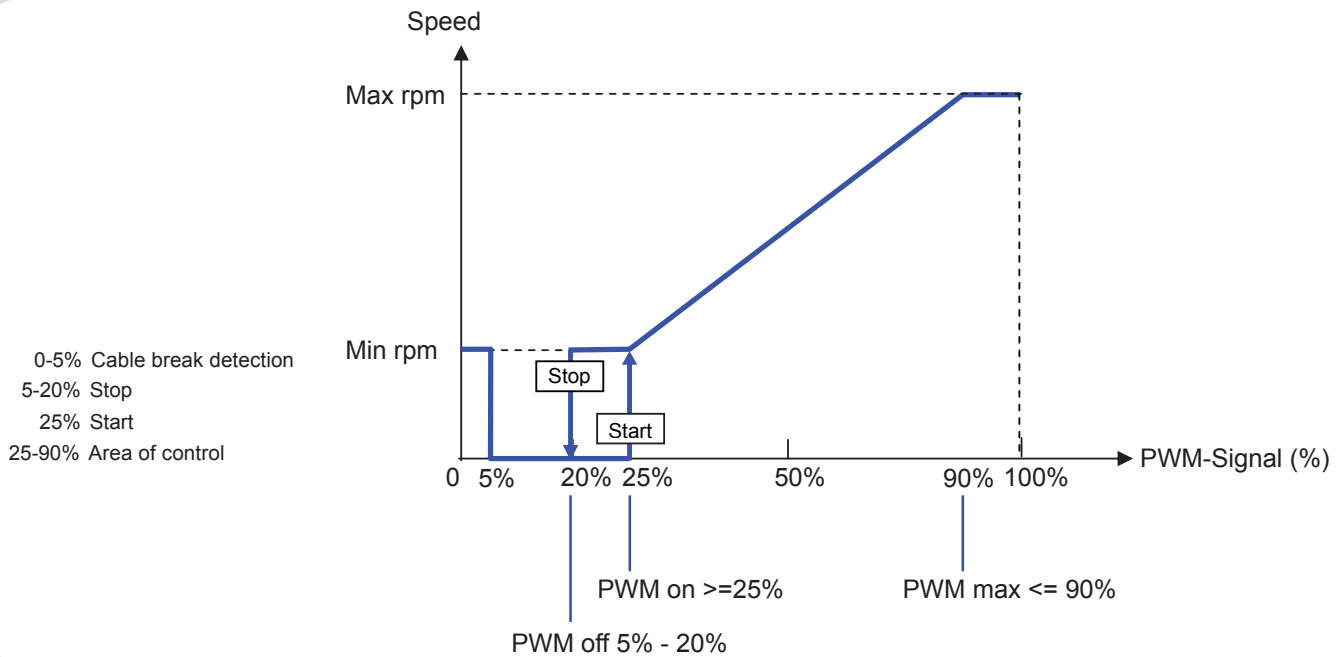

## 6.2.3b Technical data PWM and 0-10V

### Technical data PWM:

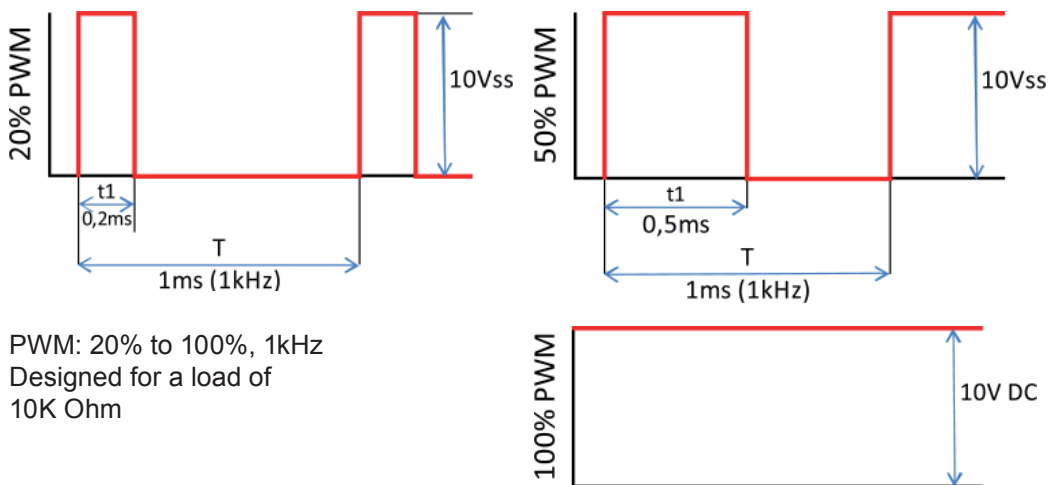

PWM: 20% to 100%, 1kHz  
Designed for a load of 10K Ohm

### Technical data 0-10V:

0-10V: 2V to 10V (20% to 100%)  
Designed for a load of 10K Ohm.

10V = 100% Speed  
5V = 50% Speed  
2V = 20% Speed  
0V = Off

## 6.2.4. - Purging time

During this time period, the pump is running with full speed (100%) to ensure trouble-free startup. After this time has passed, the pump is set to speed control and is set to max. speed or min speed, depending on the speed control variant „6.2.1. - Variant“ on page 27 chosen. Purging time can not be applied with PWM or 0-10V output.

Settings range: 5 to 600 seconds / Default setting: 8 seconds

## 6.2.5. - Sweep time

Sweep time determines the inertia of the speed control to prevent strong fluctuations in temperature. Sweep time is the timespan for a complete change from minimum to maximum pump speed.

Settings range: 1 to 15 minutes / Default setting: 4 minutes

## 6.2.6. - max. speed

The maximum speed of the pump is specified here. During the setting the pump runs at the specified speed and the flow rate can be determined.

*Settings range: 70% to 100% / Default setting: 100%*



The indicated percentages are guide values that may vary to a greater or lesser extent depending on the system, pump and pump stage.

## 6.2.7. - min. speed

The minimum speed of the pump at relay R1 is specified here. During the setting the pump runs at the specified speed and the flow rate can be determined.

*Settings range: (Speed from „On“ on page 30 ) to max. speed -5% / Default setting: 30%*



The indicated percentages are guide values that may vary to a greater or lesser extent depending on the system, pump and pump stage.. 100% is the maximum possible voltage/frequency of the controller.

## 6.2.8. - Setpoint

This value is the control setpoint for variant 3 (see „6.2.1. - Variant“ on page 27). If the value at the collector sensor drops below this, the speed is reduced. If it rises above this, the speed is increased.

*Settings range: 0° to 90°C / Default setting: 60°C*

## Relay functions

The here explained additional functions can be assigned to unused relays. Every additional function can only be used once. Pay special attention to the technical data of the relays („B.1. - Specifications“ on page 5).



### 6.3. - Solar bypass

#### Use the relay to switch a bypass valve or a bypass pump

This can direct the flow pass the storage, when the flow temperature at the bypass sensor is lower than the storage that has to be charged.

*Settings range: On; Off*

#### 6.3.1. - Variant

This menu determines whether a pump or valve is used to direct the flow through the bypass.

*Settings range: Pump, Valve / Default setting: Valve*

#### 6.3.2. - Bypass (sensor)

The flow sensor for the bypass function is selected in this menu. Do not install in the return flow.

*Settings range: S1-S8, VFS1, VFS2 / Default setting: none*



## 6.4. - Thermostat

Thermostat is used for time- and temperature controlled additional heating.

*Settings range: On, Off*



Temperature values which are set too high can lead to scalding or damage to the system. Scalding protection must be provided by the customer!



In Energy savings mode, different settings may apply, see e.g. T eco.

### 6.4.1. - TH Set

Target temperature at thermostat sensor 1. Below this temperature, additional heating is switched on, till TH set + hysteresis is reached.

*Settings range: -20 bis 99°C / Default setting: 50*

### 6.4.2. - TH hysteresis

Hysteresis of setpoint temperature.

*Settings range: 1 bis 50°C / Default setting: 10K*

### 6.4.3. - Thermostat sensor 1

T set is measured with thermostat sensor 1.

When thermostat sensor 2 is connected, the relay switches on when T set is undershot at thermostat Sensor 1, and switches off when T set + hysteresis at thermostat sensor 2 is exceeded.

*Settings range: S1-S8, VFS1-2, active storage / Default setting: none*

### 6.4.4. - Thermostat sensor 2

#### Optional switch off sensor

When T set + hysteresis is exceeded at the optional thermostat sensor 2, the relay is switched off.

*Settings range: S1-S8, VFS1-2, active storage / Default setting: none*

### 6.4.5. - T eco

For Energy saving mode

When Energy saving mode is active: During solar charge T eco is used instead of TH set. When the temperature drops below T eco at thermostat sensor 1, the relay is switched on and heats up to T eco + hysteresis.

*Settings range: 0-99°C / Default setting: 40°C*

### 6.4.6. - Storage

For Energy saving mode

Loading this storage activates the Energy saving mode

When this storage is charge by solar, additional heating is only switched on when the temperature is below T eco.

*Settings range: (Storage sensors) / Default setting: first storage*

### 6.4.7. - Energy saving mode

Energy saving mode switches the heating on when T eco is undershot und heats up to T eco + hysteresis when solar charge is active.

*Settings range: On, Off / Default setting: Off*

### 6.4.8. - Periods

#### Thermostat activity times

Set the desired periods of time when the thermostat should be active. 3 periods can be set per day, settings can also be copied to other days. Outside the set times the thermostat is switched off.

*Setting range: from 00:00 to 23:59 /default setting: 06:00 to 22:00*



## 6.5. - Cooling

This is used to cool down e.g. storages to a setpoint temperature by radiating heat.

*Settings range: S1-S8, VFS1-2, active Storage / Default setting: None*

### 6.5.1. - Co T set

Target temperature at thermostat sensor 1. Cooling is on above this temperature till Co T set + hysteresis is reached.

*Settings range: 0-99°C / Default setting: 50°C*

### 6.5.2. - Co hysteresis

If the temperature at th drops below Co T set + hysteresis, the relay is switched off.

*Settings range: -50 bis -1 / Default setting: -10*

### 6.5.3. - Cooling (sensor)

Reference sensor of the cooling function.

*Settings range: (Storage sensor) / Default setting: First storage*

### 6.5.4. - Periods

#### Cooling activity times

Set the desired periods of time when the cooling should be active. 3 periods can be set per day, settings can also be copied to other days. Outside the set times the cooling function is switched off.

*Setting range: from 00:00 to 23:59 / default setting: 06:00 to 22:00*



## 6.6. - Return flow increase

This function is used to raise the temperature of e.g. the return flow by the storage.

*Settings range: On, Off*

### 6.6.1. - RF Tmax

Maximum temperature at the storage sensor. If this temperature is exceeded, the relay is switched off.

*Settings range: 0-99°C / Default setting: 70°C*

### 6.6.2. - $\Delta T$ return flow

*Switch-on temperature difference:*

*When this difference is exceeded between return flow sensor and storage sensor, the relay is switched on.*

*Settings range: 5-20 K / Default setting: 8 K*

*Switch-off temperature difference:*

*When this difference is exceeded between return flow sensor and storage sensor, the relay is switched off.*

*Settings range: 2-19 K (limited by  $\Delta T$  Storage RF On) / Default setting: 4 K*

### 6.6.3. - Return flow (sensor)

Determines the sensor for return flow increase.

*Settings range: S1-S8, VFS1-2, active Storage / Default setting: none*

### 6.6.4. - Storage (sensor)

Determines the storage sensor

*Settings range: S1-S8, VFS1-2, active Storage / Default setting: none*



## 6.7. - Collector field cooling

This function controls an external cooling unit to cool down the collector.

*Settings range: On, Off*

### 6.7.1. - Tmax field

If this temperature is exceeded at the reference sensor, the relay is switched on.

*Settings range: 100 °C to 180 °C / Default: 120 °C*

### 6.7.2. - Hys min

When the temperature falls below Tmax field +Hys min, the relay is switched off.

*Settings range: -20 to -2°C / Default: -5*

### 6.7.3. - Hys max

To protect the cooling unit itself from damage, the relay is switched off as soon as the temperature at the reference sensor reaches Tmax field + Hys max

*Settings range: 2 to 60 °C / Default: -20*

### 6.7.4. - Field cooling sensor

Reference sensor of the collector field cooling function.

*Settings range: S1-S8, VFS1-2, active storage, RC / Default: none*



This function does not activate the solar pump to cool the collector. Therefore, please refer to the collector protection.





## 6.8. - Anti Legionella

This function is used to heat up the system during selected periods to eliminate legionella bacteria.  
*Settings range: S1-S8, VFS1-2, Active storage/ Default setting: none*

### 6.8.1. - AL T set

This temperature has to be detected for the time set in AL residence time at the AL sensors for a successful heat up.  
*Settings range: 60-99 °C / Default setting: 70°C*

### 6.8.2. - AL residence time

This determines the time span for which the AL T set temperature must be detected for a successful AL heat up.  
*Settings range: 1-120 min / Default setting: 60 min*

### 6.8.3. - Last AL heat

This displays the date and time of the last successful heat up.  
*No settings*

### 6.8.4. - AL sensor 1

This temperature is used to measure the AL temperature.  
*Settings range: S1-S8, VFS1-2, Active storage/ Default setting: none*

### 6.8.5. - AL Sensor 2

#### Optional AL sensor

When a second sensor is connected, both sensors must reach and hold the setpoint temperature for the residence time for a successful heat up.

*Settings range: S1-S8, VFS1-2, Active storage/ Default setting: none*

### 6.8.6. - AL-times

During this periods the AL heat up is attempted.

*Setting range: from 00:00 to 23:59 /default setting: 06:00 to 22:00*



Caution

This anti-Legionella function does not provide complete protection against Legionella, because the controller is dependent on sufficient energy being fed in, and it is not possible to monitor the temperatures in the entire range of the storage tanks and the connected piping system. To provide complete protection against Legionella bacteria, it must be ensured that the temperature is raised to the necessary temperature, and at the same time there must be water circulation in the storage tank and piping system by means of other additional energy sources and external control units.



Caution

The anti-Legionella function is switched off at delivery. Whenever heating-up has been carried out with the anti-Legionella function switched on, an information message with the date appears on the display.



Danger

During the anti-Legionella function the storage tank is heated up over the set value "Tmax S(X)", which can lead to scalding and damage to the system.



## 6.9. - Heat transfer

This is used to transfer energy from one storage to another with a pump.

*Settings range: S1-S8, VFS1-2, Active storage/ Default setting: none*

### 6.9.1. - $\Delta T$ Heat transfer

#### Temperature difference for heat transfer function.

When the temperature difference between HT Source and HT Drain reaches  $\Delta T$  Heat Transfer On, the relay is switched on. As soon as the difference drops to  $\Delta T$  Heat Transfer Off, the relay is switched off again.

*On: Settings range: 5-20 K/ Default setting: 8 K*

*Off: Settings range: 2 K to  $\Delta T$  Ein / Default setting: 4 K*

### 6.9.2. - Setpoint

#### Setpoint temperature of the target storage

When this temperature is detected in the target storage, heat transfer is switched off.

*Settings range: S1-S8, VFS1-2, Active storage/ Default setting: none*

### 6.9.3. - HT Tmin

#### Minimum temperature in source storage to enable the heat transfer

*Settings range: 0-90 °C / Default setting: 60°C*

### 6.9.4. - HT Source (sensor)

This menu determines the sensor, that is placed in the source storage.

*Settings range: 0-90 °C / Default setting: 30°C*

### 6.9.5. - HT Drain (Target sensor)

This determines the sensor placed in the storage that is receiving energy from the source storage.

*Settings range: S1-S8, VFS1-2, Active storage/ Default setting: none*



### 6.10. - Difference

The relay is switched on when a specific temperature difference ( $\Delta T$ ) is reached.

*Settings range: On, Off*

#### 6.10.1. - $\Delta T$ difference

##### Switch on - difference:

When this temperature difference is reached, the relay is switched on.

*Settings range: 5-20 K / Default setting: 8 K*

##### Switch off - difference:

When this temperature difference is reached, the relay is switched off.

*Settings range: 2-19 K / Default setting: 4 K (the upper limit is the switch on - difference)*

#### 6.10.2. - DF source (sensor)

##### Heat source sensor for Difference function

This determines the sensor for the heat source.

*Settings range: S1-S8, VFS1-2, Active storage/ Default setting: none*

#### 6.10.3. - Diff Tmin

##### Minimum temperature at source sensor to enable the difference relay

When the temperature at the source sensor is below this level, the difference function is disabled.

*Settings range: 0 to 90°C / Default setting: 20°C*

#### 6.10.4. - DF Drain (sensor)

##### Drain sensor / Target sensor for difference function

This determines the sensor for the target storage.

*Settings range: S1-S8, VFS1-2, Active storage/ Default setting: none*

#### 6.10.5. - DF Tmax

##### Maximum temperature at target sensor to enable difference function

If the temperature at the target sensor exceeds this value, difference function is disabled.

*Settings range: 0 to 99°C / Default setting: 60°C*



## 6.11. - Solid fuel boiler

The relay is used to control an additional solid fuel boiler.

*Settings range: On, Off*

### 6.11.1. - SF Tmax

Maximum temperature in the storage. If this is exceeded, the relay is switched off.

*Settings range: Off to 100°C / Default setting: 70° C*

### 6.11.2. - SF Tmin

Minimum temperature in the solid fuel boiler to switch on the pump. If the temperature at the boiler sensor is below this temperature, the relay is disabled.

*Settings range: 0 ° C to 100° C / Default setting: 70° C*

### 6.11.3. - Δ T SF

Switch on and Switch off condition for the temperature difference between boiler and storage.

Switch on difference Δ T SF

*Settings range: 5 to 20 K / Default setting: 8*

Switch off temperature difference Δ T SF

*Settings range: 0 K to Switch Δ T SF / Default setting: 7*

### 6.11.4. - Boiler sensor

This determines the sensor, that is used as boiler sensor.

*Settings range: S1-S8, VFS1-2, Active storage/ Default setting: none*

### 6.11.5. - Storage sensor

This determines the sensor, that is used as storage sensor.

*Settings range: S1-S8, VFS1-2, Active storage/ Default setting: none*



## 6.12. - Error message

The relay is switched on, when one or more protective function is active or a message is shown.

This function can be inverted, so that the relay is always on and switches off when a protective function or a message is shown.

*Settings range: On, Inverted, Off / Default setting: Off*

*Collector alarm*

*Collector protection*

*System protection*

*Frost protection*

*Recooling*

*Antilegionella protection*

*Message*



## 6.13. - Pressure monitor

The relay is switched on when the pressure drops below set minimum or exceeds the set maximum pressure.  
*Settings range: On, Off / Default setting: Off*

### 6.13.1. - Pressure monitor

This menu is used to configure the system pressure monitoring via direct sensor. As soon as the set limits are exceeded, the relay is switched on.

#### 6.13.1.1. - RPS1 / RPS2

##### Type of pressure sensor

This menu is used to determine the type of pressure sensor used.

Please note: If e.g. VFS1 is connected, RPS1 option is not shown.

*Settings range: Off; 0-0,6 bar; 0-1 bar; 0-1,6 bar; 0-2,5 bar; 0-4 bar; 0-6 bar; 0-10 bar*

*Default setting: Off*

#### 6.13.1.2. - Pmin

Minimum pressure. If this value is undershot, an error message is displayed and the relay is switched on (Hysteresis 0.5 bar).

*Settings range: Off; 0,0 to 1,6 bar*

*Default setting:*

#### 6.13.1.3. - Pmax

Maximum pressure. If this value is exceeded, an error message is displayed and the relay is switched on (Hysteresis 0.5 bar).

*Settings range: Off; 0,0 to 10 bar*

*Default setting: 1,6 bar*



## 6.14. - Booster pump

Additional pump that fills the system at the start of every solar charge.

*Settings range: S1-S8, VFS1-2, Active storage/ Default setting: none*

### 6.14.1. - Filling time

#### Time the pump is switched on

This setting determines the length of time the pump is switched on at the start of a solar charge.

*Settings range: 0-120 seconds / Default setting: 30 seconds*



## 6.15. - Parallel operation R (X)

The relay is switched on at the same time as the set relay R1 or R2.

*Settings range: On, Off*

### 6.15.1. - Delay

This menu determines how long after the start of R1 or R2 the parallel relay is switched on.

*Settings range: 0-120 seconds / Default setting: 30 seconds*

### 6.15.2. - Followup time

This menu determines how long after the switch off of R1 or R2 the parallel relay is switched off.

*Settings range: 0-120 seconds / Default setting: 30 seconds*



## 6.16. - Always on

Relay is always switched on.



## 6.17. - Heating circuit

Heat circuit pump is controlled with a fixed hysteresis of (+/-1° for setpoint temperature).

30 seconds Switch on and Switch off delay is fixed setting to prevent unnecessary switching of the pump.

RC21 room controller can be used as room temperature sensor.

*Settings range: On, Off*

### 6.17.1. - Room set day

Room reference temperature in day mode. If this temperature is exceeded at the room temperature sensor at the set times, the relay is switched off.

*Settings range: 10 to 30° C*

### 6.17.2. - Room set night

Room reference temperature in night mode. If this temperature is exceeded at the room temperature sensor at the set times, the relay is switched off.

*Settings range: 10 to 30° C*

### 6.17.3. - Room sensor

This menu determines the sensor for the room temperature.

*Settings range: S2 to S7, RC*

### 6.17.4. - Periods

Set the desired periods of time when the heat circuit day mode should be active. 3 periods can be set per day, settings can also be copied to other days. Outside the set times the heating function is working in night mode.

*Setting range: from 00:00 to 23:59 /default setting: 06:00 to 22:00*

## 6.18. - Heat quantity

### Constant flow

When the heat meter mode „Flow rate“ is selected, an approximated heat quantity is calculated using the values the user has to enter. These are type of glycol/AntiFreeze, glycol portion and flow rate. These values are put into correlation with the temperature data of collector sensor and storage sensor. If necessary a correction value for  $\Delta T$  can be set: Since for the heat meter the collector and the storage temperature are used, a difference to the flow respectively return flow temperature can be compensated by changing Offset  $\Delta T$  accordingly.

Example:

Displayed collector temp. 40°C, measured flow temperature 39°C, displayed storage temperature 30°C, measured return temperature 31°C = results in a correction value of -20% (displayed  $\Delta T$  10K, real  $\Delta T$  8K = -20% correction)

### VFS

When the mode VFS is selected, the direct sensor with combined temperature and flow measurement is used.



The heat quantity measured in the mode “Flow rate” is a calculated approximation for function control of the system.

### 6.18.1. - Flow sensor (X)

This determines the sensor that is used to measure the flow temperature.

*Settings range: S1-S8, VFS1-2, active collector, active storage/ Default setting: S1*

### 6.18.2. - Return sensor

This determines the sensor that is used to measure the return temperature.

*Settings range: S1-S8, VFS1-2, Aktiver Collector, Active storage/ Default setting: S1*

### 6.18.3. - Anti freeze type

Set the type of anti freeze used. If none is used, please set to 0.

*Settings range: Ethylen, Propylen / Default setting: Ethylen*

### 6.18.4. - Glycole percentage

The amount of anti freeze agent in the system.

*Settings range: 0-100% / Default setting: 45%*

### 6.18.5. - Flow rate (X)

#### Flow rate that is used to calculate the heat quantity

This determines the flow rate in litres per minute that is used for the calculation of the heat quantity.

*Settings range: 0-100 l/min / Default setting: 5 l/min*

### 6.18.6. - Offset $\Delta T$

#### Correction value for temperature difference

Since for the heat meter the collector and the storage temperature are used, a difference to the flow respectively return flow temperature can be compensated by changing Offset  $\Delta T$  accordingly.

Example:

Displayed collector temp. 40°C, measured flow temperature 39°C, displayed storage temperature 30°C, measured return temperature 31°C = results in a correction value of -20% (displayed  $\Delta T$  10K, real  $\Delta T$  8K = -20% correction)

*Settings range: -50 to +50% / Default setting: 0%*

### 6.18.7. - VFS (X)

The VFS type is set here.

*Settings range: Off; 1-12; 1-20; 2-40; 5-100; 10-200; 20-400 / Default setting: Off*

### 6.18.8. - VFS - Position

This setting determines the position of the VFS sensor.

*Settings range: flow, return / Default setting: return*



To prevent damage to the VFS sensor it is strongly recommended to install it into the return flow. If it is necessary to install in the flow, it is imperative not to exceed the maximum temperatures of the sensor! (0° C to 100°C and -25°C to 120°C short term)

### 6.18.9. - Reference sensor

The reference sensor used for the heat metering is set here.

*Settings range: S1-S8, VFS1-2, active collector, active storage/ Default setting: S1*



# Special functions

## 6.18.10. - Pressure monitor

A message is shown when the pressure drops below set minimum or exceeds the set maximum pressure. No relay is switched, for that see „7.3.20. - Pressure monitor“ on page 47.

## 6.18.11. - Pressure monitor

A message is shown and the LED flashes when the pressure deviates from the set minimum or maximum value.

*Settings range: On, Off / Default setting: Off*

### 6.18.11.1. - RPS1 / RPS2

#### Type of pressure sensor

This menu is used to determine the type of pressure sensor used.

Please note: If e.g. VFS1 is connected, RPS1 option is not shown.

*Settings range: Off; 0-0.6 bar; 0-1 bar; 0-1.6 bar; 0-2.5 bar; 0-4 bar; 0-6 bar; 0-10 bar*

*Default setting: Off*

### 6.18.11.2. - Pmin

#### Minimum pressure.

If this value is undershot, an error message is displayed and the relay is switched on.

*Settings range: Off; 0,0 to 1.6 bar*

*Default setting:*

### 6.18.11.3. - Pmax

#### Maximum pressure.

If this value is exceeded, an error message is displayed and the relay is switched on.

*Settings range: Off; 0,0 to 10 bar*

*Default setting: 1.6 bar*

## 6.19. - Sensor calibration

Deviations in the temperature values displayed, for example due to cables which are too long or sensors which are not positioned optimally, can be compensated for manually here. The settings can be made for each individual sensor in steps of 0.8°C (temperature) resp. 0.2% of the measuring range of the VFS / RPS sensor (flow rate / pressure) per step.

*Offset Sensor Settings range: -100 ... +100 / Default setting: 0*



Caution

May only be started by a specialist during commissioning! Incorrect settings may cause malfunctions.

## 6.20. - Commissioning

Starting the commissioning help guides you in the correct order through the basic settings necessary for commissioning, and provides brief descriptions of each parameter in the display.

Pressing the “esc” key takes you back to the previous value so you can look at the selected setting again or adjust it if desired. Pressing the “esc” more than once takes you back to the selection mode, thus cancelling the commissioning help.



Caution

May only be started by a specialist during commissioning! Observe the explanations for the individual parameters in these instructions, and check whether further settings are necessary for your application.

## 6.21. - Factory settings

All of the settings that have been made can be reset, thus returning the controller to its delivery state.



Caution

The entire parametrisation, analyses, etc. of the controller will be lost irrevocably. The controller must then be commissioned once again.

## Special functions

### 6.22. - SD-Card

Settings for the data logging and firmware update function with SD card.

#### 6.22.1. - Logging

Activate the logging function and set the file format used.

*Settings range: CSV, TSV, JSON, Off / Default setting: Off*

#### 6.22.2. - Free storage

Displays the available space on the SD card.

#### 6.22.3. - Load configuration

This is used to load settings from the SD card.



Current settings are over written.

#### 6.22.4. - Save configuration

All settings can be stored on the SD card.

#### 6.22.5. - Firmware update

This is used to update the controllers firmware with one saved on the SD card.



Under no circumstances switch off the controller during update, this can lead to irrevocable damages. Settings may be changed by an update. Reset the controller to factory settings after reset and commence the commissioning process.

#### 6.22.6. - Unmount

To prevent damage to the SD card or loss of data, please unmount the card before removing it from the controller.

### 6.23. - Start aid function

With some solar systems, especially with vacuum tube collectors, it may occur that the measurement value acquisition at the collector sensor occurs too slowly or too inaccurately because the sensor is often not at the hottest location. When the start help is activated the following sequence is carried out:

If the temperature at the collector sensor increases by the value specified under "Increase" within one minute, then the solar pump is switched on for the set "Purging time" so that the medium to be measured can be moved to the collector sensor. If this still does not result in a normal switch-on condition, then the start help function is subject to a 5-minute lockout time.

*Start help setting range: on, off/default setting: off*

*Purging time setting range: 2 ... 30 sec./default setting: 5 sec.*

*Increase setting range: 1°C...10°C/default setting: 3°C/min.*



This function should only be activated by a specialist if problems arise with acquisition of measurement values. In particular follow the instructions from the collector manufacturer.

### 6.24. - Time and date

This menu is used to set the current time and date.



For analysis of the system data it is essential for the time to be set accurately on the controller. Please note that the clock does not continue to run if the mains voltage is interrupted, and must therefore be reset.

### 6.25. - Daylight saving time

When this function is active, the controller's clock changes automatically to and from DST (DST, Daylight Savings Time).

### 6.26. - Sleep mode

When active, the displays backlight is switched off after 2 minutes of inactivity.

*Voreinstellung: Aus*



Caution

If a message is waiting, the backlight is not switched off.

### 6.27. - Ethernet

This menu is used to make the necessary settings for the ethernet module.

#### 6.27.1. - Ethernet

Switches the entire ethernet function on or off.

*Settings range: On, Off / Default: Off*

#### 6.27.2. - MAC Adress

Displays the actual MAC address

*No settings possible.*

#### 6.27.3. - TCP/IP Adress

This menu is used to set the IPV4 IP address of the controller.

#### 6.27.4. - Network Mask

This menu is used to set the Network mask of the connected network.

#### 6.27.5. - Gateway

This menu is used to set the IP of the standard gateway.

#### 6.27.6. - Login

This menu is used to create and manage users, who are allowed to control the SR44 via network. Up to 4 users can be created. Login name and password have to be assigned.

The following permissions are available:

**Deactivated** Access denied

**Guest** Data can be read, but no changes are possible

**Administrator** Data can be read and settings can be made.

### 6.28. - Temperature unit

This menu changes the displayed temperature unit.

*Settings range: °F or °C / Default: °C*

## 7. - Menu lock

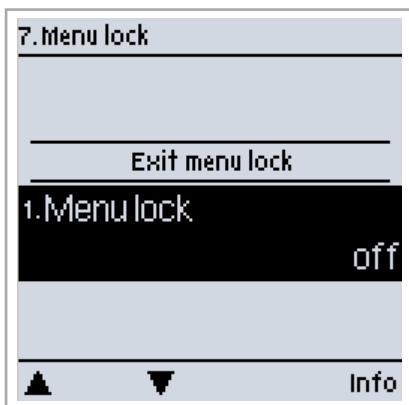

Menu “7. Menu lock” can be used to secure the controller against unintentional changing of the set values.

The menu is closed by pressing “esc” or selecting “Exit menu lock”.

The menus listed below remain completely accessible despite the menu lock being activated, and can be used to make adjustments if necessary:

1. Measurement values
2. Statistics
- 6.23. Time&date
7. Menu lock
8. Service values

To lock the other menus, select “Menu lock on”.

To enable the menus again, select “Menu lock off”.

Setting range: on, off/default setting: off

## 8. - Service values

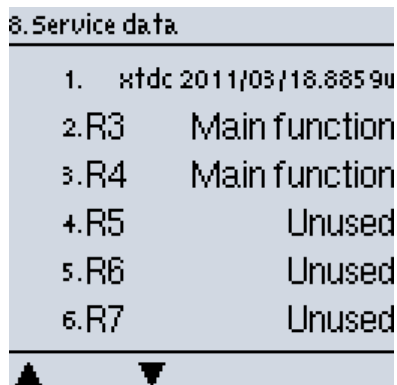

The menu „8. - Service values“ can be used for remote diagnosis by a specialist or the manufacturer in the event of an error, etc.

Service values are stored on the SD card when logging is active.

## 9. - Languages



Menu “9. Language” can be used to select the language for the menu guidance. This is queried automatically during initial commissioning.

The choice of languages may differ, however, depending on the device design.

# Malfunions

## Z.1. Malfunions with error messages

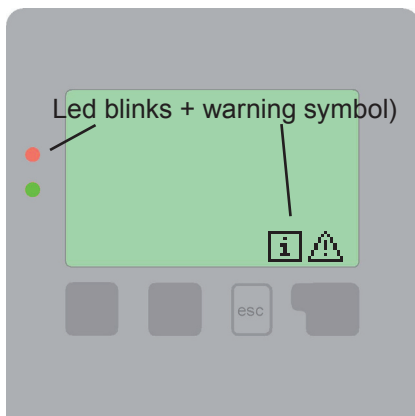

If the controller detects a malfunction, the red light flashes and the warning symbol also appears in the display. If the error is no longer present, the warning symbol changes to an info symbol and the red light no longer flashes. To obtain more detailed information on the error, press the key under the warning or info symbol.



Do not try to deal with this yourself.  
Consult a specialist in the event of an error!

Possible error messages:	Notes for the specialist:
Sensor defective	Means that either the sensor, the sensor input at the controller or the connecting cable is/was defective. (Resistance table see „B.2. - Temperature resistance table for Pt1000 sensors“ on page 5)
Collector alarm	Means that the collector has fallen/fell below the temperature set under menu „5.6. - Collector alarm“ on page 26
Restart	Means that the controller was restarted, for example due to a power failure. Check the date&time!
Time & Date	This message appears automatically after a mains failure because the time&date have to be checked, and reset if necessary.
System protection	Collector temperature overshoot the set temperature, the solar pump was switched OFF to prevent damage due to excessive heat.
Collector protection	Collector temperature overshoot the set temperature, the solar pump was switched ON to prevent damage to the collector due to excessive heat.
Recooling	Excessive heat was radiated via the collector to protect the system.
Frost protection	The solar pump was switched on to prevent damage to the collector.
Frequent on / off	When the solar pump is switched off and on more than 5 times in 5 minutes, this message is displayed.
No flow	This message is displayed when the solar pump is running and for 5 minutes the $dT \geq 50^{\circ}\text{C}$
Pressure: Failure	This message is displayed when pressure monitoring is activated and the limits Pmin or Pmax are exceeded.
SD card error	This message is displayed when an SD card is detected, but cannot be read or written on.

# Malfunctions and Maintenance

## Z.2 Replacing the fuse



Repairs and maintenance may only be performed by a specialist. Before working on the unit, switch off the power supply and secure it against being switched on again! Check for the absence of power!



Only use the supplied spare fuses or fuses of the same design with the following specifications: T2A / 250V .

If the mains voltage is switched on and the controller still does not function or display anything, then the internal device fuse may be defective. In that case, open the device as described under C, remove the old fuse and check it. Exchange the defective fuse for a new one, locate the external source of the error (e.g. pump) and exchange it. Then first recommission the controller and check the function of the switch outputs in manual mode as described under „3.2. - Manual“ on page 22

### Z.2.1

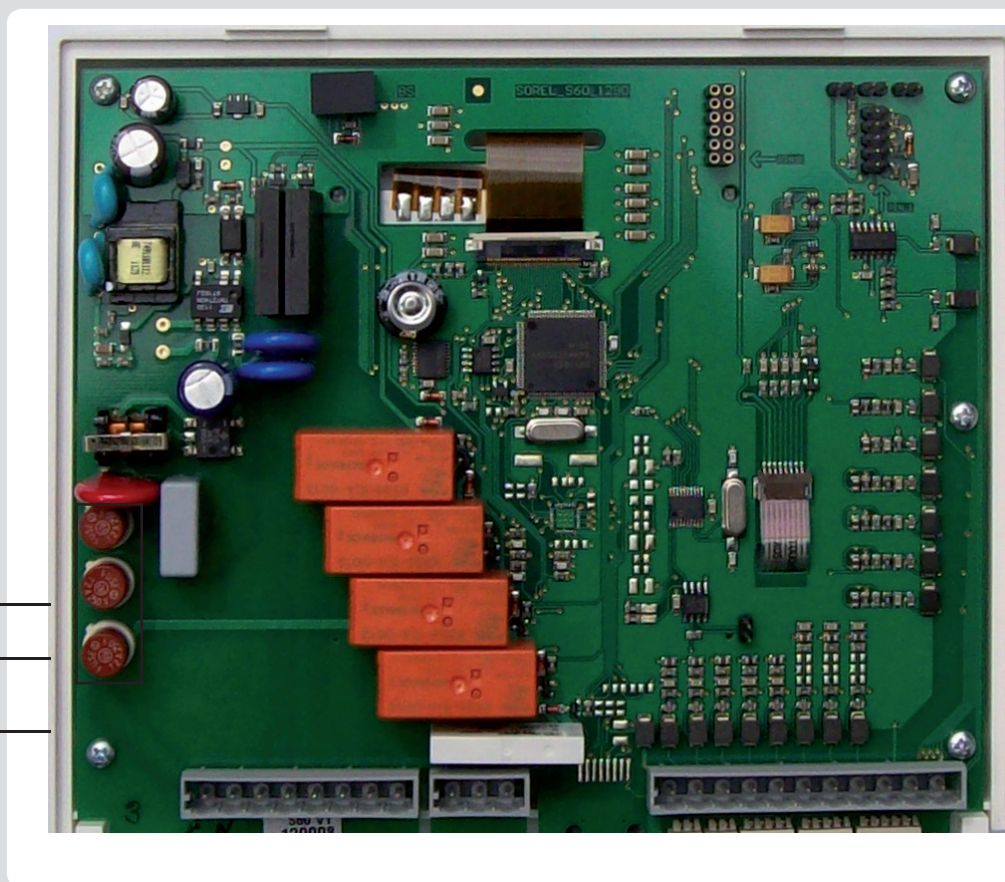

Fuses  
T2A / 250V

Main board

electronic  
relays

mechanical  
relays

## Z.3 Maintenance



In the course of the general annual maintenance of your heating system you should also have the functions of the controller checked by a specialist and have the settings optimised if necessary.

Performing maintenance:

- Check the date and time (see „6.24. - Time and date“ on page 42)
- Assess/check plausibility of analyses (see „2. - Statistics“ on page 21)
- Check the error memory (see „2.4. - Message log“ on page 21)
- Verify/check plausibility of the current measurement values (see „1. - Measurement values“ on page 21)
- Check the switch outputs/consumers in manual mode (see „3.2. - Manual“ on page 22)
- Possibly optimise the parameter settings



Instead of setting the flow rate for the system using a flow rate limiter, it is better to adjust the flow rate using the switch on the pump and by means of the “max. speed” setting on the controller (see „6.2.6. - max. speed“ on page 30). This saves electricity!



The service values (see „8. - Service values“ on page 44) include not only current measurement values and operating states, but also all of the settings for the controller. Save the service values at least once after commissioning has been successfully completed (see „6.22.4. - Save configuration“ on page 42).



In the event of uncertainty as to the control response or malfunctions the service values are a proven and successful method for remote diagnosis. Save the service values (see „8. - Service values“ on page 44.) at the time that the suspected malfunction occurs. Send the service value table with a brief description of the error to the specialist or manufacturer.



In programs with pools, the charging of the pool, e.g. for winter operation, can be switched off using a simple function. To do this, simply press and hold the “esc” key down for several seconds on the diagram/overview screen. A message appears on the display as soon as the pool is switched off or when the pool is switched on again.



To protect against loss of data, record any analyses and data that are particularly important to you (see 2.) at regular intervals.



Hydraulic variant set:

Commissioned on:

Commissioned by:

Notes:

Your specialist dealer:

Atomthreads  
Portions of the regulator firmware are Copyright (c) 2010, Kelvin Lawson. All rights reserved.

Redistribution and use in source and binary forms, with or without modification, are permitted provided that the following conditions are met:

1. Redistributions of source code must retain the above copyright notice, this list of conditions and the following disclaimer.
2. Redistributions in binary form must reproduce the above copyright notice, this list of conditions and the following disclaimer in the documentation and/or other materials provided with the distribution.
3. No personal names or organizations' names associated with the Atomthreads project may be used to endorse or promote products derived from this software without specific prior written permission.

THIS SOFTWARE IS PROVIDED BY THE ATOMTHREADS PROJECT AND CONTRIBUTORS "AS IS" AND ANY EXPRESS OR IMPLIED WARRANTIES, INCLUDING, BUT NOT LIMITED TO, THE IMPLIED WARRANTIES OF MERCHANTABILITY AND FITNESS FOR A PARTICULAR PURPOSE ARE DISCLAIMED. IN NO EVENT SHALL THE PROJECT OR CONTRIBUTORS BE LIABLE FOR ANY DIRECT, INDIRECT, INCIDENTAL, SPECIAL, EXEMPLARY, OR CONSEQUENTIAL DAMAGES (INCLUDING, BUT NOT LIMITED TO, PROCUREMENT OF SUBSTITUTE GOODS OR SERVICES; LOSS OF USE, DATA, OR PROFITS; OR BUSINESS INTERRUPTION) HOWEVER CAUSED AND ON ANY THEORY OF LIABILITY, WHETHER IN CONTRACT, STRICT LIABILITY, OR TORT (INCLUDING NEGLIGENCE OR OTHERWISE) ARISING IN ANY WAY OUT OF THE USE OF THIS SOFTWARE, EVEN IF ADVISED OF THE POSSIBILITY OF SUCH DAMAGE.

Final declaration:

Although these instructions have been created with the greatest possible care, the possibility of incorrect or incomplete information cannot be excluded. Subject as a basic principle to errors and technical changes.

XTDC\_S60\_Englisch.indd  
1358\_31\_Januar\_2013

LWIP:  
Portions of the regulator firmware are Copyright (c) 2001-2004 Swedish Institute of Computer Science.  
All rights reserved.

Redistribution and use in source and binary forms, with or without modification, are permitted provided that the following conditions are met:

1. Redistributions of source code must retain the above copyright notice, this list of conditions and the following disclaimer.
2. Redistributions in binary form must reproduce the above copyright notice, this list of conditions and the following disclaimer in the documentation and/or other materials provided with the distribution.
3. The name of the author may not be used to endorse or promote products derived from this software without specific prior written permission.

THIS SOFTWARE IS PROVIDED BY THE AUTHOR "AS IS" AND ANY EXPRESS OR IMPLIED WARRANTIES, INCLUDING, BUT NOT LIMITED TO, THE IMPLIED WARRANTIES OF MERCHANTABILITY AND FITNESS FOR A PARTICULAR PURPOSE ARE DISCLAIMED. IN NO EVENT SHALL THE AUTHOR BE LIABLE FOR ANY DIRECT, INDIRECT, INCIDENTAL, SPECIAL, EXEMPLARY, OR CONSEQUENTIAL DAMAGES (INCLUDING, BUT NOT LIMITED TO, PROCUREMENT OF SUBSTITUTE GOODS OR SERVICES; LOSS OF USE, DATA, OR PROFITS; OR BUSINESS INTERRUPTION) HOWEVER CAUSED AND ON ANY THEORY OF LIABILITY, WHETHER IN CONTRACT, STRICT LIABILITY, OR TORT (INCLUDING NEGLIGENCE OR OTHERWISE) ARISING IN ANY WAY OUT OF THE USE OF THIS SOFTWARE, EVEN IF ADVISED OF THE POSSIBILITY OF SUCH DAMAGE.